



TUNLEY
ENVIRONMENTAL

LIFE CYCLE ASSESSMENT REPORT

TRUSTED SUSTAINABILITY SCIENTISTS



LIFE CYCLE ASSESSMENT REPORT FOR

SUL4R-PLUS



SUL4R-PLUS®



Contents

Nomenclature	3
Executive Summary	4
Introduction	7
Results.....	8
Overview	8
A1-A3: Wet Raw Gypsum (Flue Gas Desulfurization)	10
Granularity of the Carbon Footprint: SUL4R-PLUS-Attributed	12
Granularity of the Carbon Footprint: Use Phase (B1) - SUL4R-PLUS-Attributed	17
Granularity of the Carbon Footprint: Use Phase (B1) - Full Biomass Flux	20
GHG Reduction Opportunities.....	25
Conclusion	26
LCA Methodology	28
Scope and Functional Unit Definition	28
Goals and Objectives.....	30
System Boundary & Allocation Procedure.....	31
LCI: Data Sources and Activity Data	33
Cut-offs, Exclusions & Assumptions.....	34
Completeness Check.....	35
Limitations.....	36
Data and Data Quality Assessment	37
Appendix A.....	39
Approval.....	48
Tunley Environmental Report Emission Statement.....	48
IMPORTANT NOTICE:	49

Nomenclature

Nomenclature	Description
GHG	Greenhouse Gases, gases that trap heat in our atmosphere. GHG include Carbon dioxide, methane, nitrous oxides, and fluorinated gases.
Embodied Carbon / Partial Product Carbon Footprint	The total GHG emissions generated to produce a product; It includes those from extraction, manufacture, processing, transportation, and assembly of every component.
Carbon Equivalent	The effect on global warming of a greenhouse gas (GHG) relative to that of CO ₂ .
Zero Carbon	The absence of GHG emissions
Greenhouse Gas Protocol	The GHG Protocol Corporate Accounting and Reporting Standard which provides requirements and guidance to prepare a corporate-level GHG emissions inventory.
Net Zero Carbon (NZC)	The sum effect of combining actions to reduce GHG emissions with actions to off-set them.
Carbon Offsetting	A reduction in emissions of GHG to compensate for unavoidable emissions.
Global Warming Potential (GWP)	The heat adsorbed by any GHG as a multiple of the equivalent in carbon dioxide.
IPCC	The Intergovernmental Panel on Climate Change. It provides regular scientific assessment on climate change to policy makers.
AR6	The sixth assessment report of the IPCC. The most recent assessment report is 2021.
t CO ₂ e	Notation for tonnes of carbon dioxide equivalent emissions.
kg CO ₂ e	Notation for kilograms of carbon dioxide equivalent emissions.
ICE	The Inventory of Carbon and Energy.
Embodied Carbon Assessment (ECA)	Embodied carbon is the carbon footprint of a material. It considers how much greenhouse gas (GHGs) is released throughout the supply chain and is often measured from cradle to (factory) gate, or cradle to handover/site (of use).
Lifecycle Assessment (LCA)	A Lifecycle Assessment (LCA) is defined as the systematic analysis of the carbon emissions of products or services during their lifecycle.
Cradle-to-gate	A partial lifecycle of a product from raw materials through to the factory's gate.
Cradle-to-handover/site	A partial lifecycle of a product from raw materials through to delivery to the customer and does not include the end-of-life processes.
Cradle-to-grave	A full single lifecycle of a product from raw materials through to its end-of-life.
Cradle-to-cradle	A lifecycle assessment including consideration of reuse of the product or material in lieu of disposal at the end of a single life-time use. Pertains to the circular economy.
Conventional tillage	A traditional farming method involving deep plowing and soil turning to prepare the seedbed.
Reduced tillage	A method that limits the depth and frequency of soil disturbance compared to conventional tillage.
No-till	A conservation practice where seeds are planted directly into undisturbed soil from previous crops.

Executive Summary

Tunley Environmental has conducted a detailed life cycle assessment to determine the carbon footprint of the SUL4R-PLUS fertilizer product. This assessment was carried out in accordance with BS EN ISO 14067:2018 and in alignment with the principles of ISO 14040 and ISO 14044. This study quantifies GHG emissions and removals associated with the full cradle-to-use life cycle of the product, with a particular focus on the use phase (Module B1), including modelled soil carbon sequestration and nitrous oxide (N₂O) emissions. The study focuses on the impact category of climate change, expressed as carbon dioxide equivalents (CO₂e), using a 100-year global warming potential (GWP100).

SUL4R-PLUS is a gypsum-based agricultural amendment, designed to improve soil structure, nutrient availability, and crop productivity. The functional unit for this assessment is defined as one acre of land treated with SUL4R-PLUS and cultivated through an entire crop cycle. The reference flow for the functional unit is based on the recommended application rate of 100 lb of SUL4R-PLUS applied per acre. The scope includes life cycle modules A1–B1: raw material extraction (A1), transport (A2), manufacturing (A3), distribution (A4), field application (A5), and the use phase (B1). Field trial data provided by SUL4R-PLUS and Tier 2 modelling methods from the IPCC and USDA underpin the use-phase emissions and sequestration calculations.

The carbon footprint for the cradle-to-gate stage (A1–A3) was calculated to be 21.77 kg CO₂e / FU. When considering all upstream stages (A1–A5) before the use phase (B1), the carbon footprint was calculated to be 25.23 kg CO₂e/FU. The use phase (B1) of SUL4R-PLUS results in net GHG removals averaging -62.79 ± 148.40 kg CO₂e/FU. This figure reflects the incremental benefit of SUL4R-PLUS relative to the untreated baseline, driven primarily by increased biomass production that enhances soil carbon sequestration (SUL4R-PLUS-attributed GHG removals). Consequently, the net life cycle impact which accounts for all modules, was calculated at -37.56 kg CO₂e per acre per crop cycle.

When considering the full biomass flux (*i.e.* both the baseline sequestration and the relative increase due to SUL4R-PLUS), the average use-phase (B1) GHG balance amounts to -779.14 ± 608.25 kg CO₂e/FU. This reflects total soil carbon sequestration and N₂O emissions under typical crop conditions. Incorporating this yields a net cradle-to-use impact of -753.91 kg CO₂e per acre per crop cycle.

Key contributors to the upstream footprint include emissions from the production of gypsum (the primary ingredient), electricity and natural gas use in manufacturing, and transport. Within the use phase, soil carbon sequestration is the largest influencing factor, with values derived from Tier 2 modelling methodologies based on SUL4R-PLUS field trial data. Nitrous oxide emissions from biomass decomposition were also accounted for.

Key findings include:

- Cradle-to-gate (A1–A3) emissions for SUL4R-PLUS are calculated at 0.22 kg CO₂e /lb, 68.1% lower compared to ammonium sulfate (0.69 kg CO₂e/lb).
- Use-phase (B1) modelling across multiple crops, U.S. regions, and tillage systems demonstrates consistent net-negative emissions, with the strongest sequestration seen in no-till systems and high-biomass yielding crops such as corn and rice.



- The inclusion of ammonium lignosulfonate within the formulation, a biogenic input, contributes significant GHG removals in Module A1, further lowering the cradle-to-gate footprint.
- The use-phase (B1), for the additional GHG removals achieved compared to the baseline scenario, shows a standard deviation of ± 148.40 kg CO₂e/FU across the sample dataset (CV = 236%).
- In the use-phase (B1) for the full biomass flux (*i.e.* both the baseline sequestration and the relative increase due to SUL4R-PLUS), shows a standard deviation of ± 608.24 kg CO₂e/FU across the sample dataset (CV = 78%), highlighting variability across soil, climate, and management conditions.
- Comparative analysis indicates that SUL4R-PLUS-treated plots outperform untreated baselines in every scenario evaluated, with enhanced sequestration and only marginal increases in N₂O emissions.
- Scenario modelling indicates that a combined approach which includes substituting natural gas and grid electricity with renewable sources and eliminating transport-related emissions could reduce cradle-to-gate emissions by up to 37%. On its own, replacing natural gas with renewable electricity for process heat would account for a 28% reduction.

It is important to note that this study is based on a single crop cycle. The modelled soil carbon sequestration values represent annual changes and do not support claims related to long-term carbon storage or crediting. Further dynamic modelling is required to assess multi-year sequestration and its permanence (e.g. with RothC or CENTURY).

The aim of this assessment is to identify major sources of emissions and removals and provide a transparent basis for evaluating the GHG performance of SUL4R-PLUS. The findings may support internal sustainability strategy development and facilitate informed engagement with stakeholders.

A summary figure of life cycle module contributions to the carbon footprint is presented below within Figure 1 (page 6).

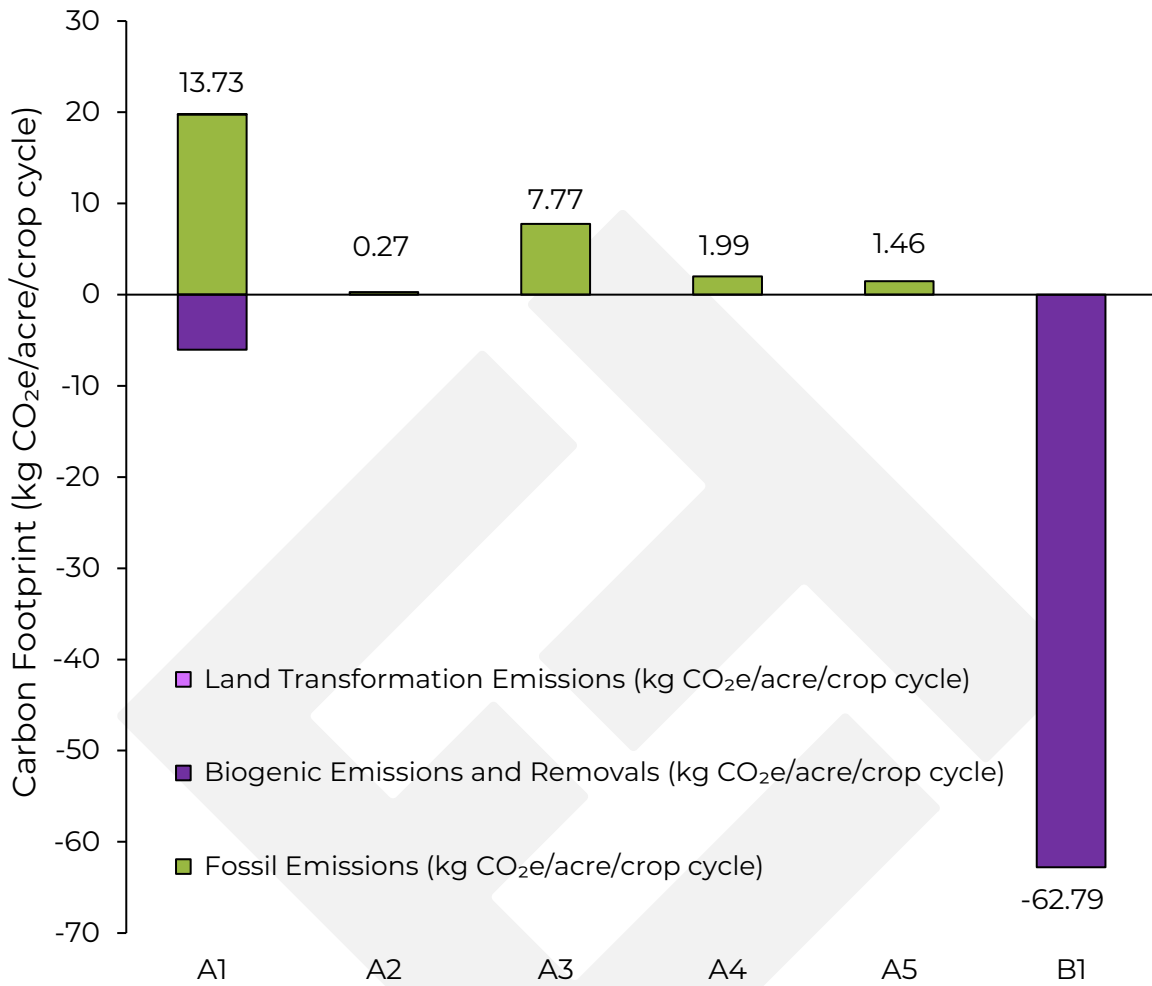

Figure 1. Breakdown of GHG emissions across life cycle stages (Modules A1–B1) attributed to SUL4R-PLUS, reported in kg CO₂e per acre per crop cycle. Module B1 reflects the incremental benefit of SUL4R-PLUS relative to the untreated baseline.

Introduction

Tunley Environmental has conducted a detailed life cycle assessment to determine the carbon footprint of the SUL4R-PLUS fertilizer product in accordance with the principles and requirements set out in BS EN ISO 14067:2018, and consistent with the broader life cycle assessment frameworks defined by ISO 14040 and ISO 14044. This study focuses on a single environmental impact category: climate change, expressed as carbon dioxide equivalents (CO₂e), using a 100-year global warming potential (GWP100).

This assessment follows a cradle-to-use scope, covering the extraction, production and transport of raw materials, production of the SUL4R-PLUS fertilizer, distribution to retail, delivery to the end user, field application, and the subsequent use phase. The use phase incorporates primary data from field trials and models soil carbon sequestration (per acre and per crop cycle) and nitrous oxide (N₂O) emissions using Tier 2 methods, consistent with those outlined in Chapter 5, Volume 4 ("Cropland") of the IPCC Guidelines, and Chapter 3 of the USDA technical report, Quantifying Greenhouse Gas Fluxes in Agriculture and Forestry: Methods for Entity-Scale Inventory (Technical Bulletin No. 1939).

This assessment aims to quantify the carbon footprint of SUL4R-PLUS over a full crop growth cycle, with a focus on identifying key emission hotspots and evaluating potential benefits to soil carbon levels. The functional unit is defined as one acre of land treated with SUL4R-PLUS and cultivated through an entire crop cycle. This approach provides a crop-specific basis for assessing fertilizer performance, using field trial data to compare SUL4R-PLUS-treated plots with untreated controls. The reference flow for the functional unit is based on the recommended application rate of 100 pounds of SUL4R-PLUS per acre.

The analysis includes the following crops: alfalfa (*medicago sativa*), corn (*zea mays*), cotton (*gossypium*), peanuts (*arachis hypogaea*), rice (*oryza sativa*), soybeans (*glycine max*), and wheat (*triticum*). Each crop was modelled in three U.S. regions using generic but representative models: the Midwest (e.g., IL, IN, OH, MI), Southeast (e.g., NC, GA, AL, FL), and Great Plains/West (e.g., SD, ND, KS, CO, UT, MT, OR, WA) under three tillage practices: conventional tillage, reduced tillage, and no-till.

This assessment quantifies soil carbon sequestration benefits of SUL4R-PLUS on an acre per crop cycle basis, in line with the defined functional unit and ISO 14067:2018 requirements. It does not represent cumulative sequestration over a multi-year horizon and therefore should not be used to support claims related to long-term carbon credits or offsets. The reported sequestration values are based on Tier 2 methodologies from the IPCC and USDA and reflect annual changes in soil carbon under typical agronomic conditions. To estimate long-term sequestration potential (e.g. over 20 or 100 years), further modelling would be required using dynamic soil carbon models such as RothC or CENTURY, which account for carbon pool turnover, saturation dynamics, and management permanence. This study focuses on a single crop cycle to maintain methodological consistency with life cycle assessment best practices and to enable robust, crop-specific results and comparison of SUL4R-PLUS impacts against untreated baselines under representative field conditions.

Tunley Environmental has used activity data provided by SUL4R-PLUS for the quantification. Where data was limited, it was supplemented where necessary by reputable secondary data sources and informed assumptions. A detailed interpretation of results is included, offering insights to support SUL4R-PLUS' internal sustainability goals and internal/external stakeholder engagement.

Results

Overview

This section offers an overview of the cradle-to-gate GHG footprint for the SUL4R-PLUS fertilizer product, focusing specifically on the impact category of climate change. The input data used to calculate the carbon footprint of products was provided by SUL4R-PLUS.

The results presented in Table 1 & Figure 2 reveal the carbon footprint associated with the SUL4R-PLUS fertilizer product. Two versions of the cradle-to-use footprint are provided. The first version models the B1 phase using emissions specifically attributable to the application of SUL4R-PLUS - that is, the incremental benefit of SUL4R-PLUS relative to the untreated baseline (labelled as SUL4R-PLUS-Attributed). The second version includes the total biomass GHG flux, encompassing both the baseline soil carbon sequestration (which would happen regardless of SUL4R-PLUS) and the incremental increase due to SUL4R-PLUS (labelled as Full Biomass Flux). The SUL4R-PLUS-Attributed footprint isolates those emissions and removals directly caused by the fertilizer product itself.

It is important to note that Module B1 represents an average across the dataset; this will be explored in more detail in later sections. The carbon footprint for the production and manufacturing stages (Modules A1–A3) of SUL4R-PLUS was calculated to be 0.22 kg CO₂e per lb of product. When considering the entire life cycle, from raw material extraction through to field application and use, the net carbon footprint attributable to the application of SUL4R-PLUS was calculated to be -37.56 kg CO₂e/acre/crop cycle. The footprint for the whole biomass (full biomass flux) was found to be -753.91 kg CO₂e/acre/crop cycle.

The sequestration is primarily driven by Module B1, which accounts for both soil nitrous oxide (N₂O) emissions and estimated soil carbon sequestration, modelled using Tier 2 methods outlined by the IPCC and USDA. The use-phase in Table 1 reports on the average of the crop dataset, with standard deviation reported in later sections. As this assessment is based on a single crop cycle, the soil carbon sequestration values represent annual changes only and are not suitable for use in carbon crediting without long-term modelling.

Table 1. Carbon footprint of the SUL4R-PLUS, reported in kilograms of carbon dioxide equivalents per functional unit (FU)

Life Cycle Module(s)	Description	Carbon Footprint, SUL4R-PLUS (kg CO ₂ e/ FU)	Functional Unit
A1 – A3	Cradle-to-Gate Emissions	0.22	kg CO ₂ e/ lb
A1 – B1	Cradle-to-Use Emissions (SUL4R-PLUS-Attributed)	-37.56	kg CO ₂ e/acre/crop cycle
A1 – B1	Cradle-to-Use Emissions (Full Biomass Flux)	-753.91	kg CO ₂ e/acre/crop cycle

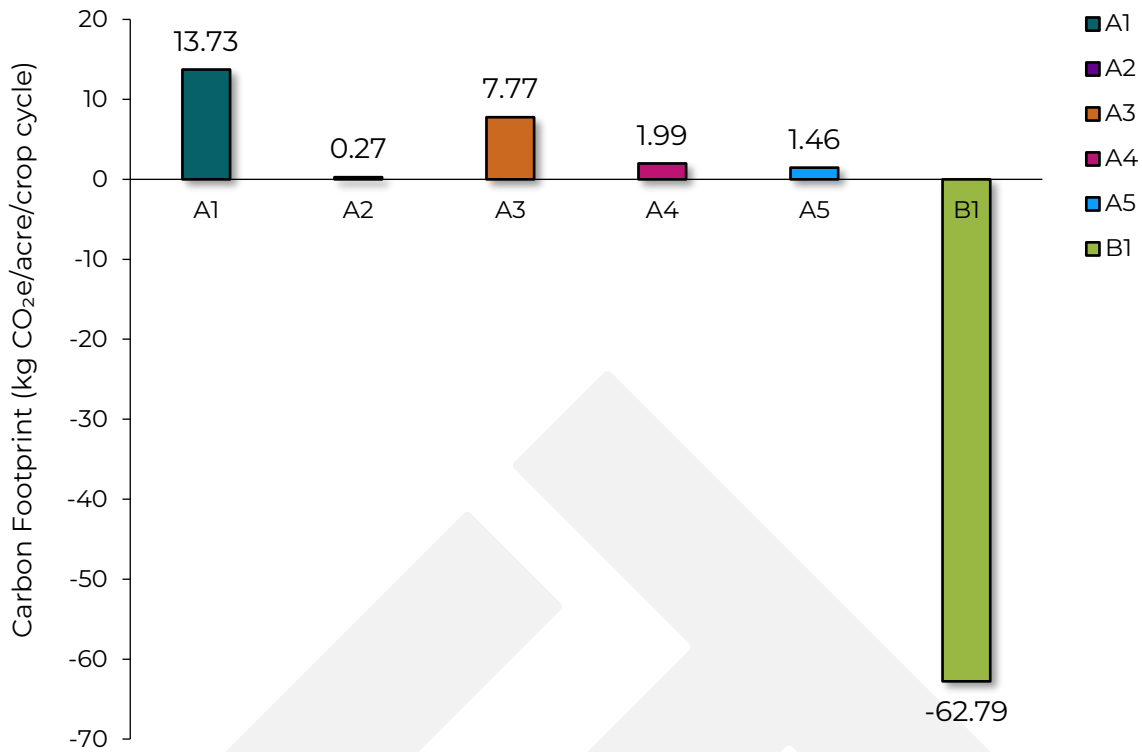

Figure 2. Contribution of life cycle stages to the carbon footprint of SUL4R-PLUS (kg CO₂e/acre/crop cycle).

At the request of SUL4R-PLUS, we have also included cradle-to-gate emissions data for the fertilizer product ammonium sulfate, sourced from the EcoInvent database and used as a benchmark in Table 2. The cradle-to-gate carbon footprint of SUL4R-PLUS was calculated to be approximately 0.47 kg CO₂e/lb lower than that of ammonium sulfate, representing a 68.1% lower carbon footprint.

Table 2. Carbon footprint of the SUL4R-PLUS and Ammonium Sulfate, reported in kilograms of carbon dioxide equivalents per lb.

Life Cycle Module(s)	Item	Carbon Footprint, (kg CO ₂ e/ FU)	Functional Unit
A1 – A3	SUL4R-PLUS	0.22	kg CO ₂ e/ lb
A1 – A3	Ammonium Sulfate	0.69	kg CO ₂ e/ lb

A1-A3: Wet Raw Gypsum (Flue Gas Desulfurization)

As part of this study, a cradle-to-gate life cycle assessment was carried out for gypsum, which is the primary component of SUL4R-PLUS. This assessment was based on publicly available data related to the generation capacity, process design, and technologies used in the flue gas desulfurization (FGD) system at the Mill Creek generating station, located in Louisville, Kentucky. This facility employs FGD to remove sulfur dioxide (SO₂) from coal combustion gases. A simplified LCA process map has been provided below in Figure 3.

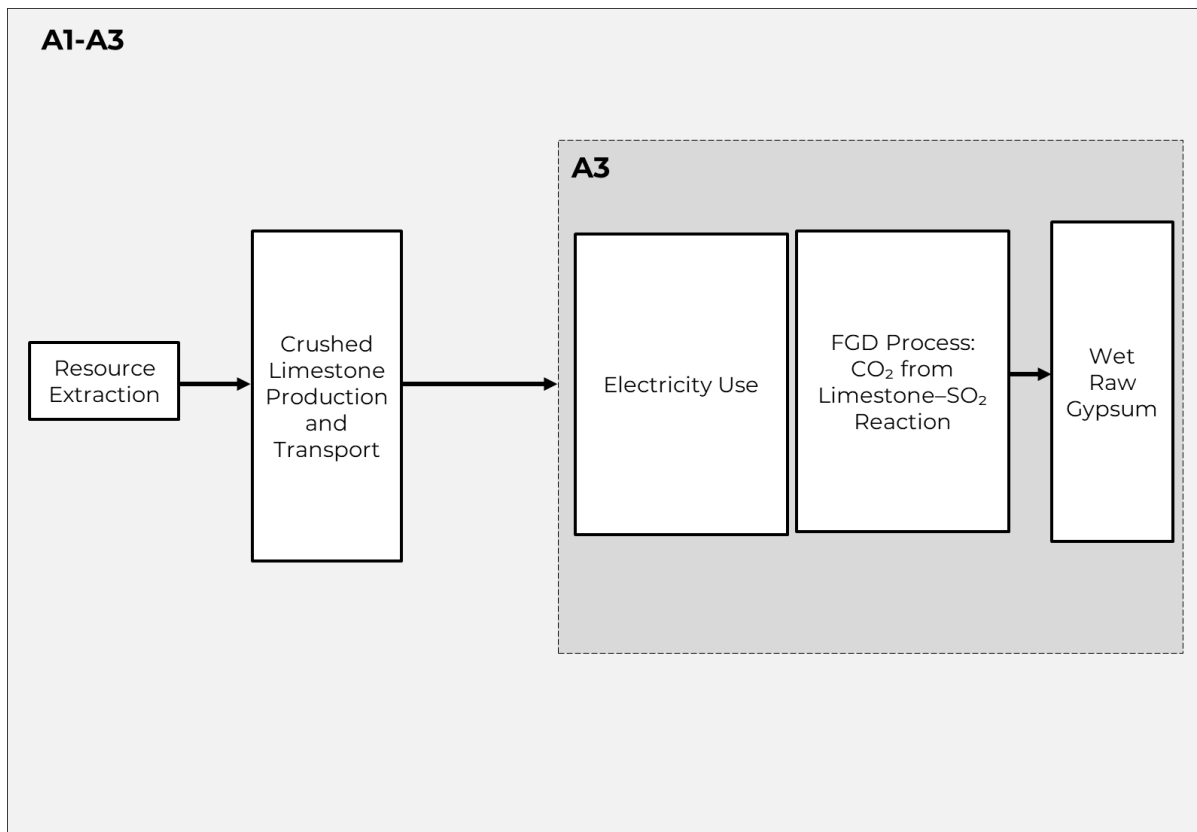

Figure 3. Life Cycle Assessment (LCA) System Boundary for Wet Raw Gypsum Production from Flue Gas Desulfurization (FGD) Process (A1-A3)

The gypsum production process was modelled using the LCA subdivision allocation procedure, treating gypsum as an independently modelled product rather than a co-product of electricity generation. This approach follows the allocation hierarchy outlined in ISO 14044, which prioritizes subdivision as the preferred method when possible. Subdivision allows for the separation of the specific processes associated with gypsum production from those of electricity generation within the FGD system. By applying this method, all relevant inputs and emissions from the FGD process are attributed solely to gypsum, ensuring a more accurate and transparent representation of its environmental profile. The model includes the following key inputs and activities:

- Crushed limestone, assumed to be quarried within 50 km of the power station and transported using a diesel truck.
- Process emissions, notably CO₂ released during the chemical reaction that converts limestone (CaCO₃) into gypsum (CaSO₄·2H₂O).

- Auxiliary electricity consumption, including energy required for material handling and water pumping, with water sourced from nearby storage ponds.

This approach ensures that the carbon footprint of gypsum used in SUL4R-PLUS reflects the specific conditions under which it is produced at Mill Creek.

Table 3 summarizes the cradle-to-gate carbon footprint of wet raw gypsum produced through the FGD process at the Mill Creek generating station. Emissions are reported in kilograms of carbon dioxide equivalents (kg CO₂e) per U.S. ton of gypsum and are categorized by life cycle modules (A1–A3) and emission sources, including fossil, biogenic, and land transformation emissions.

The total cradle-to-gate carbon footprint is 420.46 kg CO₂e per ton, with fossil emissions accounting for nearly the entire amount at 420.45 kg CO₂e. Biogenic and land transformation emissions contribute only marginally to the total. The calculated carbon footprint is consistent with values reported in the literature for gypsum produced *via* flue gas desulfurization systems, with typical emissions around 407.12 kg CO₂e per U.S. ton, as reported by EcoInvent.

Module A3, which represents gypsum production, is the largest contributor to overall emissions. This is primarily due to the chemical reaction between limestone and sulfur dioxide, which generates 281.76 kg CO₂e per ton of gypsum, as well as the auxiliary electricity consumption required to operate the FGD system, which adds an additional 130.66 kg CO₂e per ton. Module A2, covering the transport of limestone to the plant, contributes 3.90 kg CO₂e per ton, based on an assumed transport distance of 50 kilometers by diesel truck. Module A1, which includes the extraction and processing of crushed limestone, adds a relatively minor 4.14 kg CO₂e per ton.

Table 3. Carbon footprint of the wet raw gypsum as produced by Mill Creek generation station, reported in kilograms of carbon dioxide equivalents per U.S. ton of gypsum

Item	Life Cycle Module(s)	Description	Fossil Emissions (kg CO ₂ e/ton Gypsum)	Biogenic Emissions and Removals (kg CO ₂ e/ton Gypsum)	Land Transformation Emissions (kg CO ₂ e/ton Gypsum)	Total Emissions (kg CO ₂ e/ton Gypsum)
Crushed Limestone	A1	Raw Materials	4.13	1.92×10 ⁻³	8.70×10 ⁻³	4.14
Transport of Limestone to Plant	A2	Transport of Raw Materials	3.90	0.00	0.00	3.90
FGD Process: CO ₂ from Limestone–SO ₂ Reaction	A3	Manufacturing	281.76	0.00	0.00	281.76
Electricity Use	A3	Manufacturing	130.66	0.00	0.00	130.66
Cradle-to-Gate (A1-A3), Total:			420.45	1.92×10 ⁻³	8.70×10 ⁻³	420.46

Granularity of the Carbon Footprint: SUL4R-PLUS-Attributed

This section provides a deeper dive into the sources of emissions for the SUL4R-PLUS fertilizer product. Our aim is to identify the hot spots and discuss. Table 4 and Figure 4 present an overview of the cradle-to-use carbon emissions, broken down into the respective LCA modules and reported in kg CO₂e per one acre of land (kg CO₂e/acre/crop cycle) treated with SUL4R-PLUS and cultivated through an entire crop cycle. In the LCA module B1, this section focuses on emissions that are directly attributable to the application of SUL4R-PLUS, representing the incremental benefit of the product relative to the untreated baseline (labelled as SUL4R-PLUS-Attributed).

The analysis reveals that the primary hotspot is associated with the A1 life cycle module, which encompasses the extraction and processing of raw materials used in the fertilizer's formulation. This stage contributes a net 13.73 kg CO₂e/FU, comprising 19.75 kg CO₂e in fossil-based emissions, offset in part by -6.02 kg CO₂e of biogenic carbon removals, which result from the inclusion of the ammonium lignosulfonate within the formulation. A minor contribution of 0.01 kg CO₂e is also attributed to land transformation emissions within this module.

Beyond A1, the manufacturing stage accounted for in A3 emerges as the second most significant source, accounting for 7.77 kg CO₂e/FU. Emissions associated with transportation (modules A2 and A4) and field application (A5) are relatively small, collectively contributing just 3.72 kg CO₂e/FU. Specifically, raw material transport (A2) accounts for 0.27 kg CO₂e, while downstream transport (A4) and field application (A5) contribute 1.99 kg CO₂e and 1.46 kg CO₂e, respectively.

Within Module B1, which represents the use phase of the SUL4R-PLUS fertilizer product, the carbon footprint shows a net-negative impact, with mean emissions calculated at -62.79 kg CO₂e/FU (SUL4R-PLUS-Attributed). This figure reflects the average net across all crops, regions, and tillage practices which can be attributed to the application of SUL4R-PLUS and is the result of soil carbon sequestration outweighing nitrous oxide (N₂O) emissions derived from biomass decomposition. Disaggregated averages show that soil carbon sequestration attributed to SUL4R-PLUS contributes -98.38 kg CO₂e, per acre, while N₂O emissions account for +35.59 kg CO₂e per acre. These values are based on empirical field trial data provided by SUL4R-PLUS extrapolated across diverse U.S. agricultural regions and tillage regimes using IPCC Tier 2 and USDA modelling methodologies and reflect the one crop cycle.

The underlying variability of the use phase results are noteworthy. Sequestration calculations display a standard deviation of 101.30 kg CO₂e / FU, with a coefficient of variation of -1.02. Conversely, N₂O emissions show a standard deviation of 47.10 kg CO₂e / FU and a coefficient of variation of 1.32. These highlight the variability in field conditions, soil types, management practices, and climatic influences.

When considered in aggregate, the total emissions from cradle-to-application (excluding B1) amount to approximately 25.23 kg CO₂e / FU. However, the sequestration calculated in the use phase suggests that, under the right agronomic conditions, SUL4R-PLUS may function as a climate-positive fertilizer product. However, this is highly dependent on contextual factors such as soil type, biomass input quality, crop selection, and management practices.

To fully understand and validate the long-term sequestration benefits of SUL4R-PLUS, further investigation would be required. This includes modelling soil carbon dynamics over multiple decades using established tools such as the RothC or CENTURY models. These tools can simulate carbon input, decomposition, and stabilization processes over time, accounting for SOC saturation limits and changing environmental conditions. Such modelling must also consider management permanence, *i.e.*, whether practices like SUL4R-PLUS application and no-till farming are maintained consistently over time. Without this level of analysis, annual sequestration estimates cannot be assumed to deliver permanent carbon storage or support carbon credit claims. Nevertheless, the initial results indicate promising potential for SUL4R-PLUS to contribute to net reductions in greenhouse gas emissions when integrated with regenerative or conservation-oriented farming systems.

Table 4. LCA module (A1 – B1) emissions of the SUL4R-PLUS fertilizer product, reported in kilograms of carbon dioxide equivalents per functional unit (FU), one acre of land treated with SUL4R-PLUS and cultivated through an entire crop cycle. Including the standard deviation of the use phase. Module B1 This reflects the incremental benefit of SUL4R-PLUS relative to the untreated baseline.

Life Cycle Stage(s)	Description	Fossil Emissions (kg CO ₂ e / FU)	Biogenic Emissions and Removals (kg CO ₂ e / FU)	Land Transformation Emissions (kg CO ₂ e / FU)	Total Emissions (kg CO ₂ e / FU)
A1	Raw Materials	19.75	-6.02	0.01	13.73
A2	Transport of Raw Materials	0.27	0.00	0.00	0.27
A3	Manufacturing	7.77	0.00	0.00	7.77
A4	Downstream Transport	1.99	0.00	0.00	1.99
A5	Application to Field	1.46	0.00	0.00	1.46
B1	Use Phase	0.00	-62.79 ± 148.40	0.00	-62.79 ± 148.40
Cradle-to-Use (A1-B1), Total:		31.24	-68.81 ± 148.40	0.01	-37.56 ± 148.40

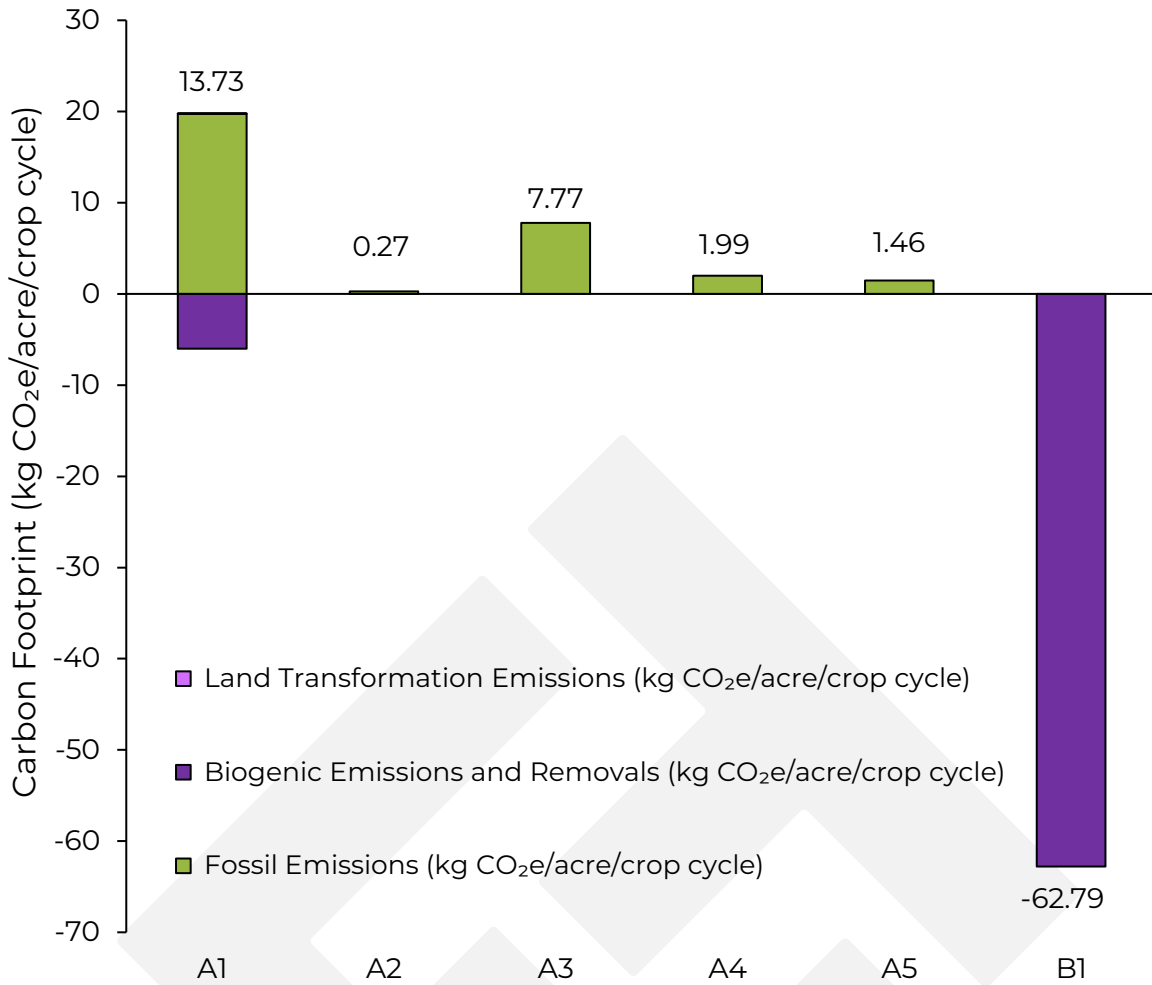

Figure 4. Breakdown of GHG emissions across life cycle stages (Modules A1–B1) attributed to SUL4R-PLUS, reported in kg CO₂e per acre per crop cycle. Module B1 is reflective of the incremental benefit of SUL4R-PLUS relative to the untreated baseline.

Table 5 (on page 16) provides a detailed breakdown of GHG emissions across the life cycle stages of the SUL4R-PLUS fertilizer product, disaggregated by material and energy inputs, transport stages, application, and modeled use-phase outcomes. All emissions are reported in kg CO₂e/FU, where the FU is defined as one acre of land treated with SUL4R-PLUS and cultivated over a full crop cycle. Module B1 This reflects the incremental benefit of SUL4R-PLUS relative to the untreated baseline.

Within the A1 module (raw material acquisition and processing), the largest contributor to fossil GHG emissions is wet raw gypsum, which accounts for 14.64 kg CO₂e/FU, with negligible associated biogenic and land transformation emissions. The ammonium lignosulfonate solution has a more complex profile, with 4.61 kg CO₂e/FU in fossil emissions, but a significant biogenic carbon removal of -6.02 kg CO₂e/FU, resulting in net negative emissions of -1.40 kg CO₂e/FU. This highlights the carbon-sequestering potential of biogenic materials when included in product formulations. Red waxy corn oil contributes marginally to overall emissions, with a total of 0.50 kg CO₂e/FU, most of which is fossil-based.

Transport-related emissions captured under the A2 and A4 modules are minimal but non-negligible. Transport of ammonium lignosulfonate (A2) is the highest in this category at

0.24 kg CO₂e/FU, followed by transport of red waxy corn oil (0.03 kg CO₂e/FU) and gypsum (0.01 kg CO₂e/FU). Downstream distribution covering both transport to the retailer and to the customer adds a combined 1.98 kg CO₂e/FU under the A4 module.

Under the A3 module (manufacturing), energy inputs from natural gas and electricity contribute significantly to emissions. Natural gas use is responsible for 6.05 kg CO₂e/FU, while electricity accounts for an additional 1.72 kg CO₂e/FU, making A3 the second-largest contributor. The A5 module, representing application of the product in the field, contributes a further 1.46 kg CO₂e/FU, encompassing emissions associated with diesel use within agricultural machinery.

In the B1 use phase, soil carbon sequestration (attributed to SUL4R-PLUS), driven by biomass inputs associated with crop growth and SUL4R-PLUS application, results in -98.38 kg CO₂e /FU, with a standard deviation of ±101.30. This represents the single largest GHG removal in the life cycle and is based on extrapolated SUL4R-PLUS field trial data modeled using USDA and IPCC Tier 2 methodologies. Conversely, attributed nitrous oxide (N₂O) emissions from soil due to biomass decomposition are estimated at +35.59 kg CO₂e/FU (±47.10), reflecting variability due to site conditions, tillage, and crop type.

When aggregated, the cradle-to-use carbon footprint of the SUL4R-PLUS product totals 31.24 kg CO₂e/FU in fossil emissions, -68.81 kg CO₂e /FU in biogenic removals, and 0.01 kg CO₂e/FU from land transformation, resulting in a net life cycle impact of -37.56 kg CO₂e/FU. This suggests that, under modeled conditions, the SUL4R-PLUS product has the potential to contribute to net-negative emissions, primarily through its enhancement of soil carbon sequestration. However, as previously stated to fully understand and validate the long-term sequestration benefits of SUL4R-PLUS, further investigation would be required.

Table 5. Granularity of the LCA modules (A1 – B1) emissions for the SUL4R-PLUS fertilizer product, reported in kilograms of carbon dioxide equivalents per functional unit (FU): one acre of land treated with SUL4R-PLUS and cultivated through an entire crop cycle. Including the standard deviation of the use phase. Module B1 reflects the incremental benefit of SUL4R-PLUS relative to the untreated baseline.

Item	Life Cycle Module(s)	Fossil Emissions (kg CO ₂ e/FU)	Biogenic Emissions and Removals (kg CO ₂ e/FU)	Land Transformation Emissions (kg CO ₂ e/FU)	Total Emissions (kg CO ₂ e/FU)
Wet Raw Gypsum	A1	14.64	6.67×10 ⁻⁵	3.03×10 ⁻⁴	14.64
Ammonium Lignosulfonate Solution	A1	4.61	-6.02	5.93×10 ⁻³	-1.40
Red Waxy Corn Oil	A1	0.49	6.99×10 ⁻⁴	1.42×10 ⁻³	0.50
Transport of Wet Raw Gypsum	A2	0.01	-	-	0.01
Transport of Ammonium Lignosulfonate	A2	0.24	-	-	0.24
Transport of Red Waxy Corn Oil	A2	0.03	-	-	0.03
Natural Gas	A3	6.05	-	-	6.05
Electricity	A3	1.72	-	-	1.72
Transport to Retailer	A4	1.72	-	-	1.72
Transport from Retailer to Customer	A4	0.26	-	-	0.26
Application to Field	A5	1.46	-	-	1.46
Soil Carbon Sequestration (from biomass)	B1	-	-98.38 ± 101.30	-	-98.38 ± 101.30
N ₂ O Emissions (soil, from biomass)	B1	-	35.59 ± 47.10	-	35.59 ± 47.10
	Cradle-to-Use (A1-B1), Total:	31.24	-68.81 ± 148.40	0.01	-37.56 ± 148.40

Granularity of the Carbon Footprint: Use Phase (B1) - SUL4R-PLUS-Attributed

The use phase (Module B1) of the SUL4R-PLUS life cycle assessment (LCA) is a key aspect of the product's carbon footprint, therefore, we will discuss this in further detail within this section. The use phase accounts for two main soil-based GHG fluxes: (1) soil carbon sequestration, modelled using crop-specific input data, and (2) nitrous oxide (N₂O) emissions, resulting from biomass decomposition. The N₂O emissions were modelled using two components, namely, nitrogen leaching (indirect) and nitrogen volatilization (direct). The use module was modelled Tier 2 methods, consistent with those outlined in Chapter 5, Volume 4 ("Cropland") of the IPCC Guidelines, and Chapter 3 of the USDA technical report, Quantifying Greenhouse Gas Fluxes in Agriculture and Forestry: Methods for Entity-Scale Inventory (Technical Bulletin No. 1939).

To capture geographic and agronomic variability, this analysis includes the following crops: alfalfa, corn, cotton, peanuts, rice, soybeans, and wheat, each modelled across three major U.S. agricultural regions using generic but representative models: Midwest (e.g. IL, IN, OH, MI), Southeast (e.g. NC, GA, AL, FL), and Great Plains/West (e.g. SD, ND, KS, CO, UT, MT, OR, WA). Reported under three tillage regimes: conventional tillage, reduced tillage, and no-till.

This section evaluates the comparative performance of SUL4R-PLUS against baseline (untreated) conditions (SUL4R-PLUS-Attributed) during the use phase (Module B1), focusing on the two principal components: soil carbon sequestration and nitrous oxide (N₂O) emissions. Baseline values were derived from control plots in SUL4R-PLUS field trials and are detailed in Appendix A, Tables A6–A7.

Table 6 (page 18) presents the marginal gains or losses in GHG emissions per functional unit (in kg CO₂e/acre/crop cycle) associated with the application of SUL4R-PLUS compared to the baseline controls. Results are disaggregated by crop type, region, and tillage regime. Negative values indicate improved GHG performance (i.e. additional sequestration or reduced emissions) compared to the baseline. This can also be found in graphical form in Figure A2. The net emissions and removals attributed to SUL4R-PLUS are reported in Table 7 (page 19).

Across all crops, regions, and tillage systems, the application of SUL4R-PLUS consistently resulted in greater carbon sequestration within the soil compared to the baseline. The largest relative gains in sequestration were observed in alfalfa, particularly under no-till in the Midwest, with an additional -473.99 kg CO₂e/acre captured compared to the baseline. Even crops with lower overall carbon sequestration potential, such as wheat and soybeans, still showed modest but consistent sequestration gains across all locations (e.g. -36.64 kg CO₂e/acre for soybeans in the Midwest under no-till). This suggests that SUL4R-PLUS promotes increased biomass production, leading to greater retention of organic matter and enhanced root biomass inputs across a variety of agroecological settings. The effect is strongest when used in tandem with conservation tillage systems, which improve the stability of sequestered carbon.

In contrast, the modelled application of SUL4R-PLUS did lead to slight increases in N₂O emissions relative to the baseline. However, these increases were relatively small in magnitude, especially for non-leguminous crops (e.g. corn, soybean, wheat) and consistent across tillage systems. This reflects the fact that enhanced biomass productivity can lead to greater microbial activity and denitrification in the soil. Nevertheless, the modest N₂O increases are far outweighed by the gains in carbon sequestration across all systems.

Table 6. Differences in soil carbon sequestration and nitrous oxide emissions between SUL4R-PLUS-treated plots and untreated baselines during the use phase (Module B1). Results are reported in kg CO₂e per acre per crop cycle and disaggregated by crop type, region, and tillage practice. Negative values represent GHG reductions relative to the baseline.

Crop Type	Location	Difference to Baseline: Soil Carbon Sequestration			Difference to Baseline: Biogenic Emissions
		Conventional Till (kg CO ₂ e/FU)	Reduced Till (kg CO ₂ e/FU)	No-till (kg CO ₂ e/FU)	N ₂ O Emissions (kg CO ₂ e/FU)
Alfalfa	Midwest states	-364.60	-419.29	-473.99	143.35
Alfalfa	Southeast states	-248.59	-285.88	-323.17	143.35
Alfalfa	Great Plains/Western states	-215.45	-247.77	-280.08	143.35
Corn	Midwest states	-25.72	-29.58	-33.43	3.35
Corn	Southeast states	-17.53	-20.16	-22.79	3.35
Corn	Great Plains/Western states	-15.20	-17.48	-19.76	3.35
Cotton	Midwest states	-98.06	-112.76	-127.47	34.29
Cotton	Southeast states	-66.86	-76.88	-86.91	34.29
Cotton	Great Plains/Western states	-57.94	-66.63	-75.32	34.29
Peanut	Midwest states	-116.05	-133.45	-150.86	38.42
Peanut	Southeast states	-79.12	-90.99	-102.86	38.42
Peanut	Great Plains/Western states	-68.57	-78.86	-89.15	38.42
Rice	Midwest states	-115.35	-132.65	-149.96	19.79
Rice	Southeast states	-78.65	-90.45	-102.24	19.79
Rice	Great Plains/Western states	-68.16	-78.39	-88.61	19.79
Soybean	Midwest states	-28.18	-32.41	-36.64	3.62
Soybean	Southeast states	-19.22	-22.10	-24.98	3.62
Soybean	Great Plains/Western states	-16.65	-19.15	-21.65	3.62
Wheat	Midwest states	-42.50	-48.87	-55.24	6.33
Wheat	Southeast states	-28.97	-33.32	-37.67	6.33
Wheat	Great Plains/Western states	-25.11	-28.88	-32.64	6.33

Table 7. Net GHG emissions from the use phase (Module B1) of SUL4R-PLUS-Attributed emissions, representing the combined effect of soil carbon sequestration and N₂O emissions. Values are reported per acre per crop cycle and disaggregated by crop, region, and tillage type.

Crop Type	Location	Net GHG Emissions		
		Conventional Till (kg CO ₂ e/FU)	Reduced Till (kg CO ₂ e/FU)	No-till (kg CO ₂ e/FU)
Alfalfa	Midwest states	-221.26	-275.95	-330.64
Alfalfa	Southeast states	-105.25	-142.53	-179.82
Alfalfa	Great Plains/Western states	-72.10	-104.42	-136.73
Corn	Midwest states	-22.37	-26.22	-30.08
Corn	Southeast states	-14.18	-16.81	-19.44
Corn	Great Plains/Western states	-11.85	-14.13	-16.41
Cotton	Midwest states	-63.76	-78.47	-93.18
Cotton	Southeast states	-32.57	-42.59	-52.62
Cotton	Great Plains/Western states	-23.65	-32.34	-41.03
Peanut	Midwest states	-77.63	-95.03	-112.44
Peanut	Southeast states	-40.70	-52.57	-64.44
Peanut	Great Plains/Western states	-30.15	-40.44	-50.72
Rice	Midwest states	-95.56	-112.87	-130.17
Rice	Southeast states	-58.86	-70.66	-82.46
Rice	Great Plains/Western states	-48.38	-58.60	-68.82
Soybean	Midwest states	-24.56	-28.79	-33.02
Soybean	Southeast states	-15.60	-18.48	-21.36
Soybean	Great Plains/Western states	-13.03	-15.53	-18.03
Wheat	Midwest states	-36.16	-42.54	-48.91
Wheat	Southeast states	-22.64	-26.99	-31.33
Wheat	Great Plains/Western states	-18.78	-22.54	-26.31

Granularity of the Carbon Footprint: Use Phase (B1) - Full Biomass Flux

This section presents the GHG emissions results for the full biomass flux, which accounts for all crop biomass, including both the baseline soil carbon sequestration (which would occur without SUL4R-PLUS), and the additional sequestration attributed to SUL4R-PLUS. This perspective situates the product's impact within the broader agricultural context for each crop type across three major U.S. agricultural regions: the Midwest (e.g. IL, IN, OH, MI), the Southeast (e.g. NC, GA, AL, FL), and the Great Plains/West (e.g. SD, ND, KS, CO, UT, MT, OR, WA). Results are reported under three tillage regimes: conventional tillage, reduced tillage, and no-till. This reflects variability in agricultural practices. Tables A9–A10, alongside Figure A3, provide detailed breakdowns of the full emission profile for this total biomass flux scenario.

The granular breakdown in Table 8 (page 21) and Figure 5 (page 22) show soil carbon sequestration and associated N₂O emissions for each scenario. In general, no-till systems achieve the highest sequestration rates across all crops and regions due to greater residue retention and minimal soil disturbance. Corn and rice in the Midwest emerge as the most effective combinations for net soil carbon capture, showing sequestration values exceeding -2,000 kg CO₂e/FU in no-till systems. In contrast, crops such as wheat and cotton in the Great Plains/Western states demonstrate more modest sequestration.

While sequestration dominates the overall balance, N₂O emissions are significant, particularly in leguminous or nitrogen-fixing crops such as alfalfa and peanuts, which show the highest N₂O emission rates across regions. These emissions were held constant by crop type but vary in relative impact depending on sequestration magnitude. The main driver of the N₂O emissions is the nitrogen content of the biomass left on the field. Furthermore, there are management strategies to mitigate nitrogen losses, such as the use of nitrification inhibitors which can help mitigate the N₂O emissions.

Table 8. Soil carbon sequestration and nitrous oxide (N₂O) emissions modelled for the use phase (Module B1) of SUL4R-PLUS application, full biomass flux. Results are disaggregated by crop type, U.S. region, and tillage practice, reported in kg CO₂e per acre per crop cycle (functional unit).

Crop Type	Location	Soil Carbon Sequestration			Biogenic Emissions
		Conventional Till (kg CO ₂ e/FU)	Reduced Till (kg CO ₂ e/FU)	No-till (kg CO ₂ e/FU)	N ₂ O Emissions (kg CO ₂ e/FU)
Alfalfa	Midwest states	-1,299.49	-1,494.41	-1,689.33	510.91
Alfalfa	Southeast states	-886.01	-1,018.92	-1,151.82	510.91
Alfalfa	Great Plains/Western states	-767.88	-883.06	-998.24	510.91
Corn	Midwest states	-1,862.68	-2,142.08	-2,421.48	242.65
Corn	Southeast states	-1,270.01	-1,460.51	-1,651.01	242.65
Corn	Great Plains/Western states	-1,100.67	-1,265.77	-1,430.87	242.65
Cotton	Midwest states	-915.19	-1,052.46	-1,189.74	320.05
Cotton	Southeast states	-623.99	-717.59	-811.19	320.05
Cotton	Great Plains/Western states	-540.79	-621.91	-703.03	320.05
Peanut	Midwest states	-1,231.89	-1,416.67	-1,601.45	407.86
Peanut	Southeast states	-839.92	-965.91	-1,091.90	407.86
Peanut	Great Plains/Western states	-727.93	-837.12	-946.31	407.86
Rice	Midwest states	-1,695.51	-1,949.83	-2,204.16	290.83
Rice	Southeast states	-1,156.03	-1,329.43	-1,502.84	290.83
Rice	Great Plains/Western states	-1,001.89	-1,152.17	-1,302.46	290.83
Soybean	Midwest states	-967.61	-1,112.75	-1,257.89	124.28
Soybean	Southeast states	-659.73	-758.69	-857.65	124.28
Soybean	Great Plains/Western states	-571.77	-657.53	-743.30	124.28
Wheat	Midwest states	-560.73	-644.84	-728.95	83.58
Wheat	Southeast states	-382.32	-439.67	-497.01	83.58
Wheat	Great Plains/Western states	-331.34	-381.04	-430.74	83.58

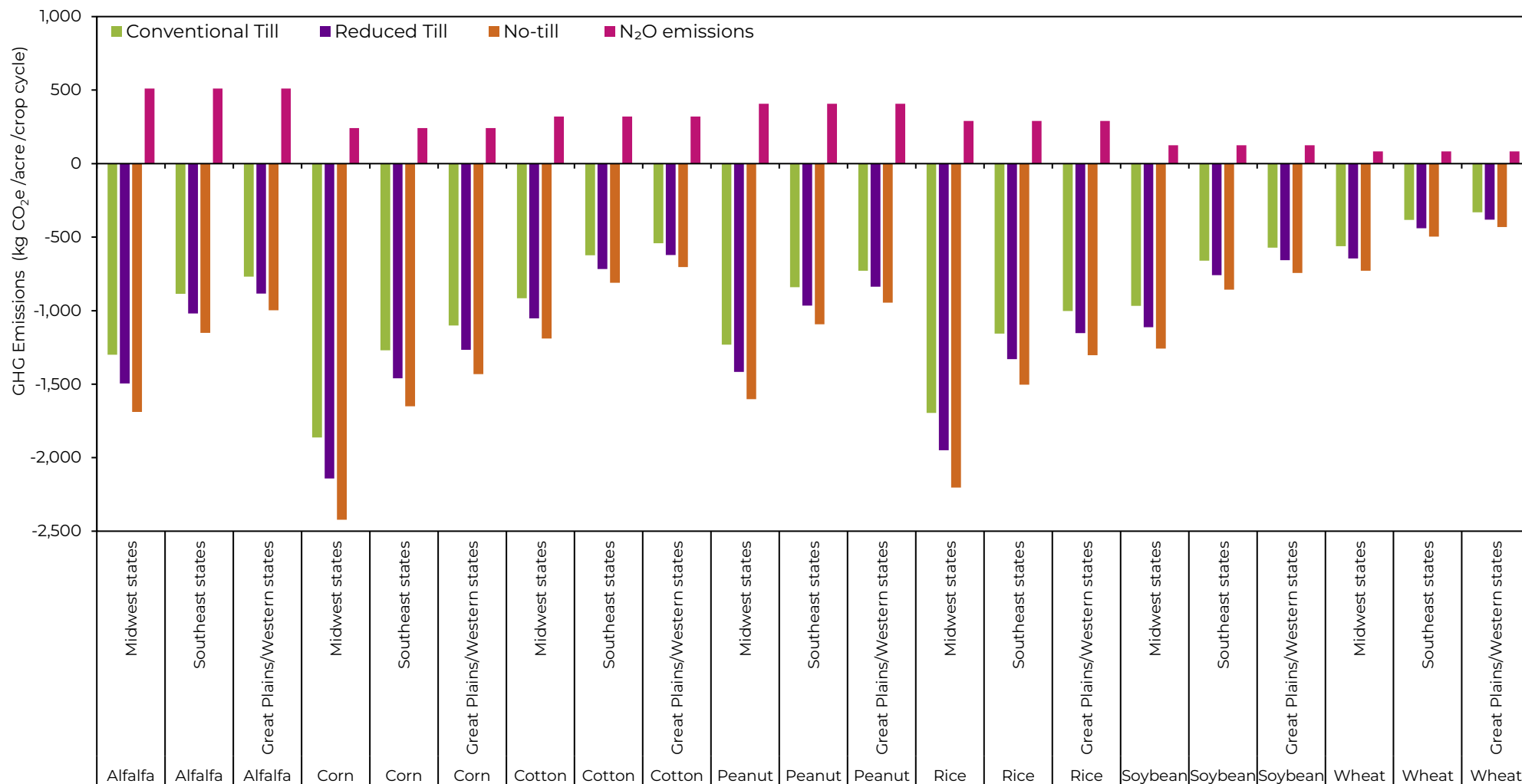

Figure 5. GHG emissions during the use phase (Module B1) of SUL4R-PLUS application, full biomass flux., disaggregated by crop, U.S. region, and tillage type. Emissions are reported in kg CO₂e per acre per crop cycle. Bars represent soil carbon sequestration under conventional tillage (green), reduced tillage (purple), and no-till (orange), with nitrous oxide (N₂O) emissions displayed separately (pink) to illustrate the relative impact of soil-based emissions versus carbon removals. Full Biomass Flux.



The net GHG emissions from the use phase inclusive of the full biomass flux are shown in Table 9 (page 24). Every crop-region-tillage combination modelled resulted in net-negative emissions. The extent of the sequestration is directly tied to biomass productivity, tillage intensity, and soil-climate context.

Tillage intensity has a pronounced effect on magnitude of carbon sequestration. In nearly all crop and region combinations, a clear gradient is observed. No-till practices consistently show the highest levels of soil carbon sequestration, followed by reduced tillage, with conventional tillage sequestering the least.

The gradient of sequestration aligns with established soil science literature, which finds that minimizing soil disturbance helps preserve soil organic matter and increases the incorporation of crop residues into stable soil carbon pools. For example, the analysis shows corn grown in the Midwest under no-till sequesters -2,421.48 kg CO₂e/acre, compared to -1,862.68 kg CO₂e/acre under conventional tillage, a difference of approximately 30%.

Sequestration values are consistently highest in the Midwest, followed by the Southeast, with the Great Plains/Western states showing the lowest values for most crops and tillage types. This pattern is likely driven by:

- Soil type differences (e.g., Mollisols in the Midwest have higher SOC potential),
- Climate conditions, at locations where climates were cooler and moister this supported greater biomass inputs and slower decomposition.

There is substantial variation in sequestration across crops, with corn, rice, and alfalfa consistently showing the highest sequestration potential, while wheat and cotton perform at the lower end. These differences are primarily driven by:

- Biomass productivity, as the higher-yielding crops return more carbon to the soil.
- Root-to-shoot ratios and residue characteristics which influence below-ground biomass weight and residue decomposition rates.

Table 9. Net GHG emissions from the use phase (Module B1) of SUL4R-PLUS, full biomass flux, representing the combined effect of soil carbon sequestration and N₂O emissions. Values are reported per acre per crop cycle and disaggregated by crop, region, and tillage type.

Crop Type	Location	Net GHG Emissions		
		Conventional Till (kg CO ₂ e/FU)	Reduced Till (kg CO ₂ e/FU)	No-till (kg CO ₂ e/FU)
Alfalfa	Midwest states	-788.58	-983.50	-1,178.42
Alfalfa	Southeast states	-375.10	-508.01	-640.91
Alfalfa	Great Plains/Western states	-256.97	-372.15	-487.33
Corn	Midwest states	-1,620.02	-1,899.43	-2,178.83
Corn	Southeast states	-1,027.35	-1,217.86	-1,408.36
Corn	Great Plains/Western states	-858.02	-1,023.12	-1,188.22
Cotton	Midwest states	-595.14	-732.42	-869.70
Cotton	Southeast states	-303.94	-397.54	-491.14
Cotton	Great Plains/Western states	-220.74	-301.86	-382.98
Peanut	Midwest states	-824.03	-1,008.81	-1,193.60
Peanut	Southeast states	-432.06	-558.05	-684.04
Peanut	Great Plains/Western states	-320.08	-429.27	-538.46
Rice	Midwest states	-1,404.67	-1,659.00	-1,913.33
Rice	Southeast states	-865.19	-1,038.60	-1,212.00
Rice	Great Plains/Western states	-711.06	-861.34	-1,011.62
Soybean	Midwest states	-843.33	-988.47	-1,133.61
Soybean	Southeast states	-535.46	-634.42	-733.38
Soybean	Great Plains/Western states	-447.49	-533.26	-619.02
Wheat	Midwest states	-477.15	-561.26	-645.37
Wheat	Southeast states	-298.73	-356.08	-413.43
Wheat	Great Plains/Western states	-247.76	-297.46	-347.16

GHG Reduction Opportunities

As part of the lifecycle assessment, Tunley Environmental aims to identify key contributors to the product's GHG footprint and evaluate opportunities for meaningful reductions. Figure 6 illustrates the comparative GHG emissions from SUL4R-PLUS production under baseline and four decarbonization scenarios, all assessed within the cradle-to-gate scope (A1-A3) and scaled to the FU, one acre of SUL4R-PLUS treated land over a full crop cycle.

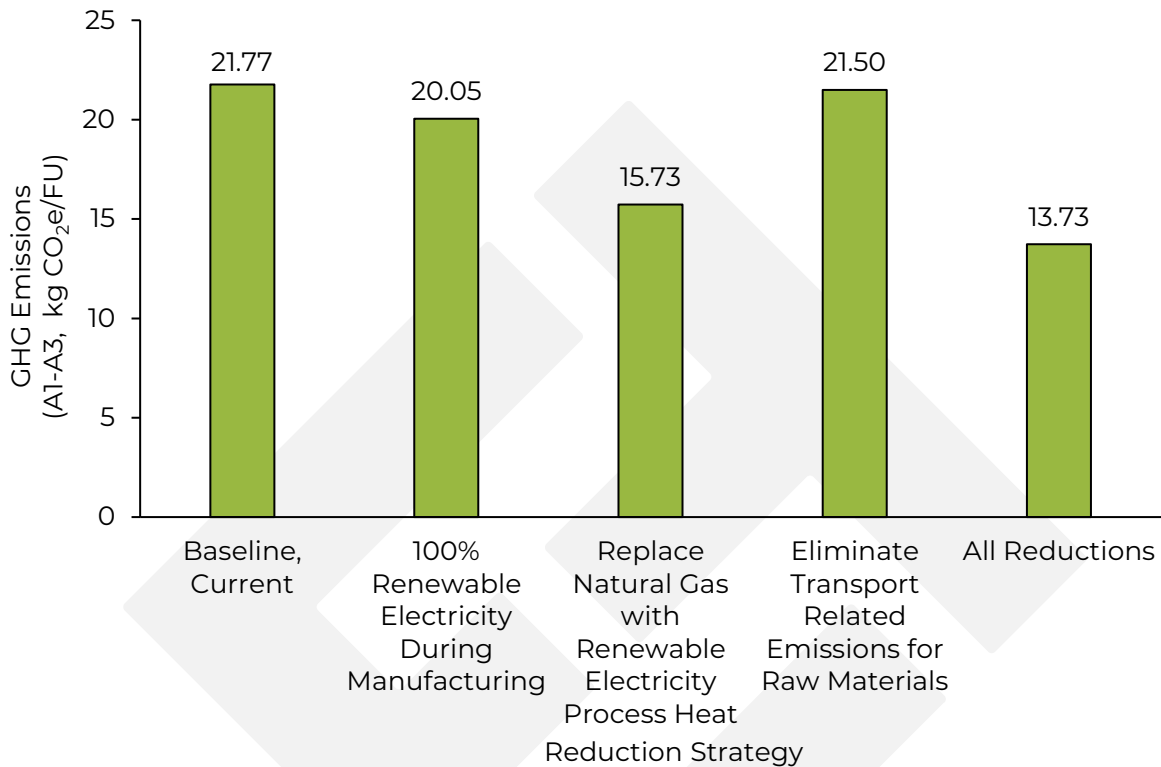

Figure 6. GHG emission reduction potential for SUL4R-PLUS under various decarbonization strategies within the cradle-to-gate boundary (Modules A1-A3), expressed per functional unit (one acre treated through one crop cycle).

The baseline scenario, reported throughout this report, results in a GHG footprint of 21.77 kg CO₂e per functional unit. Replacing electricity used during manufacturing with 100% renewable sources yields a modest improvement, reducing emissions to 20.05 kg CO₂e/FU (a ~7.9% reduction). A more impactful initiative involves replacing natural gas with renewable electricity for process heat, which drops emissions significantly to 15.73 kg CO₂e/FU, representing a ~27.7% reduction from baseline. Eliminating raw material transport emissions (while useful) has comparatively less impact, with emissions only slightly reduced to 21.50 kg CO₂e/FU.

The greatest reduction is achieved when all strategies are combined, cutting emissions to 13.73 kg CO₂e/FU, an overall 37% reduction compared to the current manufacturing baseline. These calculations suggest that decarbonizing process heat and electricity inputs offer the greatest leverage for carbon savings, while transport-related interventions yield smaller but complementary benefits.

Conclusion

This study has quantified the cradle-to-use GHG emissions associated with the SUL4R-PLUS fertilizer product, following the requirements of BS EN ISO 14067:2018 and aligned with the ISO 14040/14044 framework. The functional unit was defined as one acre of land treated with SUL4R-PLUS at the recommended application rate and cultivated through a single crop cycle.

This product carbon footprint assessment of the SUL4R-PLUS fertilizer has identified both the key sources of greenhouse gas emissions and the relative contributions of each life cycle stage, from raw material extraction through to in-field application and use.

The carbon footprint for the cradle-to-gate stage (A1–A3) was calculated at 21.77 kg CO₂e/FU. When including all upstream stages (A1–A5) before the use phase (B1), the footprint increases slightly to 25.23 kg CO₂e/FU. The use phase (B1) of SUL4R-PLUS results in net GHG removals averaging -62.79 ± 148.40 kg CO₂e/FU, representing the incremental benefit of the product relative to the untreated baseline (SUL4R-PLUS-attributed GHG removals), driven by increased biomass production and enhanced soil carbon sequestration. This yields a net life cycle impact of -37.56 kg CO₂e per acre per crop cycle when accounting for all modules from raw material extraction to use.

The majority of upstream emissions are driven by raw material extraction (13.73 kg CO₂e/FU) and manufacturing (7.77 kg CO₂e/FU), with minor contributions from transport and application.

When considering the full biomass flux (*i.e.* both the baseline sequestration and the incremental increase due to SUL4R-PLUS), the average use-phase (B1) GHG balance amounts to -779.14 ± 608.25 kg CO₂e/FU. This value captures the total soil carbon sequestration and N₂O emissions under typical crop conditions. This yields a net cradle-to-use impact of -753.91 kg CO₂e per acre per crop cycle.

The results indicate that under the conditions modelled, the use of SUL4R-PLUS may lead to a net reduction in GHG emissions on a per-cycle basis. However, this outcome is dependent on crop type, soil conditions, tillage practices, and climate. It should also be noted that the sequestration values reflect short-term changes only and are not indicative of long-term carbon storage. To investigate this, further research using dynamic soil carbon models (e.g. RothC or CENTURY) would be required to assess multi-year sequestration and its permanence.

Three primary areas for emissions reductions were explored within the cradle-to-gate boundary:

- Substituting natural gas for renewable electricity to reduce process heat emissions during manufacturing,
- Using 100% renewable electricity in place of grid electricity,
- Minimizing transport emissions by optimizing logistics or sourcing materials locally.

The combined implementation of these decarbonization strategies could reduce cradle-to-gate emissions by up to 37%, lowering the footprint from 21.77 kg CO₂e/FU to 13.73 kg CO₂e/FU. The greatest contribution to this reduction is attributed to the replacement of fossil-based process heat.



The goal of the study was to identify the main contributors to the product's GHG footprint and provide a basis for understanding its performance was achieved. The quality of primary and secondary data used is considered appropriate for the study scope.

Overall, the study provides a robust and transparent baseline for understanding the climate-related impacts of SUL4R-PLUS and offers actionable insights to inform internal sustainability strategies, stakeholder engagement, and potential alignment with regenerative agricultural practices.



LCA Methodology

The life cycle assessment (LCA) of the SUL4R-PLUS fertilizer product was conducted in accordance with the requirements of BS EN ISO 14067:2018, and in a manner consistent with the broader international LCA frameworks defined by ISO 14040 and ISO 14044. This section outlines the mandatory components of the assessment, including system boundaries, data sources, allocation procedures, impact assessment methods, and assumptions, in line with criteria established by the standards.

The results of the carbon footprint calculations reveal the potential impact of each emitted greenhouse gas on climate change. This impact is expressed using the IPCC Global Warming Potential indicator, which utilizes a 100-year time frame and presents the impact in kg CO₂e per functional unit

Scope and Functional Unit Definition

The primary objective of this assessment is to quantify the greenhouse gas (GHG) emissions associated with the production and use of SUL4R-PLUS, with a focus on the impact category of climate change, expressed in carbon dioxide equivalents (CO₂e) using a 100-year Global Warming Potential (GWP100) as specified by the IPCC.

The functional unit (FU) for this study is defined as: “One acre of land treated with SUL4R-PLUS (at the recommended application rate, corresponding to the reference flow, 100 lb/acre) and cultivated through a complete crop cycle.”

This cradle-to-use assessment includes all relevant life cycle modules: from raw material extraction and processing (A1), transport (A2), manufacturing (A3), distribution (A4), application (A5), and use-phase (B1), specifically capturing carbon sequestration and N₂O emissions. End-of-life stages (C1–C4) and beyond-use credits (D) are excluded from the scope as they are not material, and the study is focused on in-field use-phase impacts over a single crop cycle.

This was a lifecycle assessment aiming to cover all material sources of emissions during the study. Materiality in this context is defined as anything contributing more than an estimated 1% of total lifecycle GHG footprint. A full outline of all lifecycle modules, their description, and the materiality of them in this assessment is provided in Table A1 (page 29).

Table A1. Materiality assessment and notation for quantified LCA categories.

LCA Category	Data Category Description	Materiality
A1 Raw Materials	Embodied carbon of the raw materials, chemicals, and components used.	Material – quantified.
A2 Transport	Emissions from the upstream transportation of the components or raw materials to the manufacturing facility.	Material – quantified.
A3 Manufacturing	Emissions from the manufacturing processes used in production of the product.	Material – quantified.
A4 Transport to site	Emissions from transportation of the final product to the consumer.	Material – quantified.
A5 Installation / Implementation	Installation or implementation processes and related emissions.	Material – quantified.
B1 Use/Application	This is in relation to usage-based emissions not categorized as water or energy.	Material – quantified.
B2 Maintenance	Regular expected maintenance of the equipment over the lifetime including all components, travel, electricity, etc.	Non-Material – Outside of scope.
B3 Repair	Emissions related to the repair of any broken-down equipment. Is it the parts, travel, service time, etc.	Non-Material – Outside of scope.
B4 Replacement	Emissions associated with any wholly replaced items.	Non-Material – Outside of scope.
B5 Refurbishment	Emissions associated with the refurbishment of end-of-life items to extend expected lifetime.	Non-Material – Outside of scope.
B6 Operational Energy Use	Emissions associated with energy usage of the item/equipment over its lifetime.	Non-Material – Outside of scope.
B7 Operational Water Use	Emissions associated with water usage of the item/equipment over its lifetime.	Non-Material – Outside of scope.
C1 Deconstruction	Emissions associated with any deconstruction processes.	Non-Material – Outside of scope.
C2 Transport	Emissions associated with the transportation of the item/equipment at end-of-life.	Non-Material – Outside of scope.
C3 Waste Processing	Emissions associated with recycling processes for materials at end-of-life.	Non-Material – Outside of scope.
C4 Disposal	Emissions associated with non-recycling disposal scenarios for materials at end-of-life.	Non-Material – Outside of scope.
D Benefits and loads	Any notable reductions or offsets through the products operation e.g. biogenic sequestration or energy generation.	N/A

Goals and Objectives

This report presents the results of a life cycle carbon footprint assessment conducted by Tunley Environmental for the fertilizer product SUL4R-PLUS, in accordance with the principles and requirements set out in BS EN ISO 14067:2018, and in alignment with the broader life cycle frameworks defined in ISO 14040 and ISO 14044.

The assessment covers a cradle-to-use system boundary, with specific focus on the use phase (Module B1), incorporating modelled estimates of soil carbon sequestration and nitrous oxide (N₂O) emissions under realistic agronomic conditions. The impact category evaluated is climate change, expressed using 100-year Global Warming Potentials (GWP100) as defined in the IPCC Fifth Assessment Report (AR5).

The goal of this assessment is to quantify the climate-related environmental impact of SUL4R-PLUS fertilizer when applied under common agricultural conditions in the United States. The assessment was designed to achieve the following objectives:

1. To quantify the cradle-to-use carbon footprint of SUL4R-PLUS per acre per crop cycle, encompassing raw material extraction, production, transport, field application, and use-phase emissions and removals.
2. To evaluate the contribution of the use phase (Module B1) to the overall carbon footprint, specifically through modelled soil carbon sequestration and N₂O emissions using Tier 2 methodologies from the IPCC and USDA.
3. To compare SUL4R-PLUS performance to untreated baselines, using SUL4R-PLUS field trial data across multiple crops, regions, and tillage systems, thereby identifying benefits or trade-offs.
4. To inform internal sustainability strategy for SUL4R-PLUS and provide a transparent, standards-compliant basis for potential external communication with value chain partners and stakeholders.

The results of this study are intended to:

- Inform internal decision-making and product strategy regarding the environmental performance of SUL4R-PLUS,
- Support stakeholder engagement with distributors, agricultural partners, and sustainability-focused customers,
- Provide an evidence base for further life cycle thinking, including the potential for regenerative agriculture integration or long-term soil carbon modelling (e.g. RothC or CENTURY),
- Serve as a baseline for subsequent impact reduction or offsetting strategies.

This report is primarily intended for internal use by SUL4R-PLUS. It may also be used to engage with external stakeholders, including supply chain partners, or clients, within a controlled and transparent communication framework.

A one-peer internal critical review was conducted by independent LCA experts within Tunley Environmental to ensure methodological robustness and conformance to ISO 14067:2018. The review verified that:

- The functional unit and system boundaries are clearly defined and appropriate,
- The calculations and report are free of errors
- The use of primary and secondary data is transparent and justified,
- The impact assessment is consistent with ISO standards,
- Key limitations and assumptions are explicitly stated.

System Boundary & Allocation Procedure

The system boundaries encompass all unit processes that contribute measurably to the objective of the study. The system boundary is "cradle-to-use", and includes all relevant unit processes associated with:

- Raw material acquisition and transport (A1–A2)
- Fertilizer manufacturing (A3)
- Distribution to point of sale and field delivery (A4)
- On-field application using standard machinery (A5)
- In-field GHG dynamics including soil carbon sequestration and nitrous oxide emissions (B1)

In this study, except where otherwise noted, all relevant, required, and known materials and processes were included in the life cycle inventory. All cut-offs and assumptions are clearly stated and described in the subsequent Cut-offs, Exclusions & Assumptions section. For transparency a general system boundary with all inputs and processes is provided in Figure 7 (page 32)

The gypsum component of SUL4R-PLUS was modelled using subdivision allocation, wherein gypsum is treated as a stand-alone output from the FGD process at the Mill Creek power station. All associated upstream emissions, including limestone transport, chemical reactions, and electricity were attributed fully to gypsum.

No economic or mass-based co-product allocation was used in this study. The SUL4R-PLUS product is the sole product produced during the manufacturing stage and there are no byproducts.

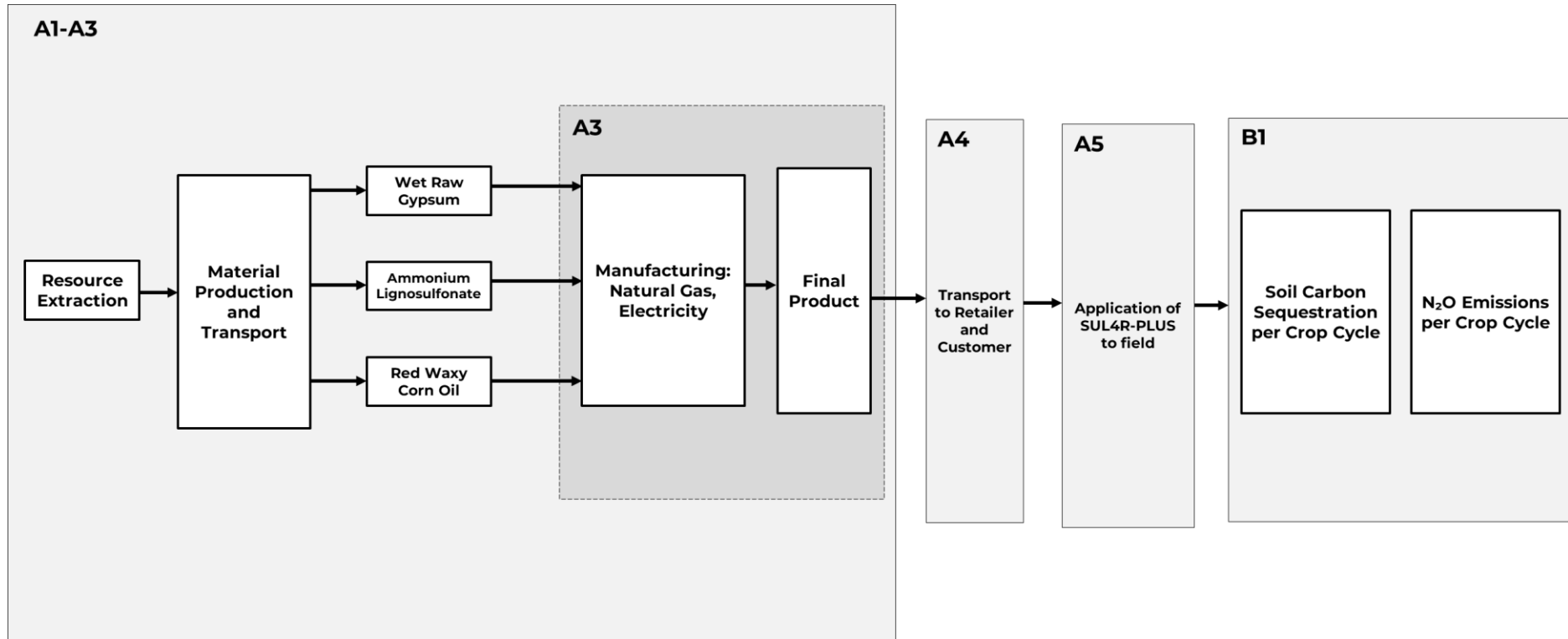

Figure 7. System boundary for the cradle-to-use life cycle assessment of SUL4R-PLUS, covering Modules A1 to B1 in accordance with BS EN ISO 14067:2018. The figure illustrates upstream material extraction and processing (A1), transportation (A2), manufacturing with energy inputs (A3), distribution to retailer and end user (A4), field application (A5), and the use-phase (B1), which includes soil carbon sequestration and nitrous oxide (N₂O) emissions modelled per crop cycle.



LCI: Data Sources and Activity Data

To assess the carbon footprint of the SUL4R-PLUS product, two types of data are utilized: activity data and emission data. Specific activity data (primary data) was gathered by SUL4R-PLUS where feasible. Where specific data was not available, reasonable assumptions were made using relevant databases and expertise. Description of primary data supplied by SUL4R-PLUS to Tunley is provided in full in Table A2.

Table A2. COMPANY data provided for lifecycle analysis.

Data	Description	Units
Weight of the Raw Materials (Formulation)	The weight and material formulation of the SUL4R-PLUS product was provided by SUL4R-PLUS	lb
Electricity, Gas and Water Use	Details on the utility use was provided by SUL4R-PLUS	kWh, CCF
Location of Raw Materials and Transport	Details on the location where raw materials and products were sourced and dispatched was provided by SUL4R-PLUS. Tunley Environmental used the text field to calculate the distances using Google Maps	t.km
Field Trial Data for Use-phase	SUL4R-PLUS provided Tunley Environmental with several years of field trials and a meta-analysis which informed the use-phase calculations	Mg/ha

Inputs are modelled based on primary activity data provided by SUL4R-PLUS, supplemented by secondary LCI data from Ecoinvent, Agri-footprint, and published USDA/IPCC reports.

This LCA relied on a combination of primary (site-specific) and secondary (generic) data:

- Primary data were supplied by SUL4R-PLUS and its partners, including:
- Material inputs and formulation
- Field trial data for biomass inputs and application rates
- Crop-specific performance data

Secondary data were drawn from reputable sources such as:

- Ecoinvent database for ammonium sulfate benchmarking
- Agri-footprint database
- IPCC 2006 Guidelines (Vol. 4, Chapter 5 – Cropland)
- USDA Technical Bulletin No. 1939 for Tier 2 emissions and SOC methods
- 2024 DESNZ and US EPA for transport and energy emissions
- Product specific EPD data was used for the Ammonium Lignosulfonate Solution

All carbon equivalency factors were applied using GWP100 values from the IPCC AR6, or AR5 where data availability is limited.

Cut-offs, Exclusions & Assumptions

This assessment applies the cut-off approach, whereby processes contributing less than 1% to total GHG impact are excluded in line with ISO 14067 and typical LCA practice. All relevant input and output flows have been included to the best of our knowledge, with the following assumptions applied:

System Boundary and Scope

- Capital goods and infrastructure (e.g. manufacturing of machinery or buildings) are excluded from the assessment, consistent with standard LCA boundary practice.
- Off-site storage, packaging, and retail energy consumption are not included.
- Land use change (LUC) is not modelled beyond carbon changes from soil sequestration under the gypsum amendment scenarios.

Agronomic and Application Assumptions

- A standard gypsum application rate of 100 lb/acre was applied uniformly across all crop types and regions. This is based on the recommended application rate but may vary depending on farming practices and location.
- Machinery fuel use for application (Module A5) assumes 1 US gallons of diesel per 7 acres, based on contractor estimates.
- All biomass and yield data are assumed to be reported on a dry mass basis per USDA sources. No further moisture correction was required.
- Yield improvements from gypsum application are assumed to be constant year-on-year for the purpose of carbon modelling.

Transport Modelling

- All relevant transport stages (Modules A2, A4) are included.
- Transport distances were calculated using Google Maps and assigned to typical modes (medium and heavy-duty trucks).
- Final delivery from retailer to field (A4) assumes a 50 km delivery radius.
- Rail and barge modes distances were assumed to be the same as road distances, due to limited routing data.

Biomass and Soil Carbon (Module B1)

- Biomass carbon content is crop-specific, using peer-reviewed values (e.g. 45% for corn and wheat, 58% for soybean).
- Root-to-Shoot ratios were obtained from Table 3-3 of the USDA, Chapter 3: Quantifying Greenhouse Gas Sources and Sinks in Cropland and Grazing Land Systems
- SOC conversion efficiency (humification) factors were modelled using peer-reviewed values for each region modelled. Corrections were applied to these to represent tillage practices to obtain final values.
- Corrected SOC conversion efficiency (humification) factors are region- and tillage-specific:
 - Midwest: 0.22 (conventional), 0.25 (reduced), 0.286 (no-till)
 - Southeast: 0.15 (conventional), 0.17 (reduced), 0.2 (no-till)
 - Great Plains/West: 0.13 (conventional), 0.15 (reduced), 0.17 (no-till)
- SOC conversion values are sourced from multiple sources, including RothC, CENTURY, USDA TB1939, and peer-reviewed studies.
- Nitrogen content of residues is crop-specific and derived from USDA and IPCC defaults. Where missing (e.g. peanut roots), above-ground values were assumed.
- N₂O emissions (direct and indirect) are modelled using IPCC 2006 Tier 2 equations, including emissions from residue-N input and nitrogen leaching/volatilization.

Representativeness and Data Quality

- Data reflects 2024 production conditions and agronomic practices.
- Regional modelling uses USDA-defined zones for the Midwest, Southeast, and Great Plains/Western states, with climate and soil data matched accordingly.
- SOC and yield responses to gypsum are extrapolated from SUL4R-PLUS field trials and literature; results may vary under other soil, climate, or management conditions.

Completeness Check

All relevant processes contributing measurably to the cradle-to-use carbon footprint were included. The combination of primary and regionally appropriate secondary data ensures a representative, reproducible, and standards-compliant footprint for SUL4R-PLUS. Overall, the carbon footprints are deemed to be calculated with sufficient representativeness and accuracy concerning both system boundaries and data completeness, in alignment with the goal and scope of the assessment. The data used for calculating the carbon footprint comprises either SUL4R-PLUS-specific primary data or generic data from databases that meet the set requirements for data quality, thus ensuring representativeness for the studied system.

Limitations

The methodology employed encompasses only one impact category, Climate Change, which assigns a single score to the product's impact. However, this approach overlooks other environmental aspects, leading to a restricted perspective. Impacts beyond the climate change category (e.g., eutrophication, biodiversity) are excluded from scope.

Other limitations include:

- The assessment models soil organic carbon (SOC) sequestration and nitrous oxide (N₂O) emissions over a single annual crop cycle. Long-term carbon dynamics, pool turnover, inter-annual variability, and permanence are not considered.
- No decay or decline in yield benefit is modelled over time; increases are assumed to persist year-on-year, potentially overestimating sustained carbon benefits.
- SOC conversion efficiencies are region- and tillage-specific but derived from literature. These introduce uncertainty, as actual SOC formation depends on local conditions such as soil texture, clay content, microbial activity, and land use history.
- Tillage effects are represented using uniform correction factors based on published studies, which may not fully reflect variability in field practices (e.g. depth, frequency, equipment differences).
- Application of gypsum and its impacts on yield and SOC are assumed to be consistent across all regions. However, response is known to vary with baseline soil chemistry, subsoil acidity, calcium availability, and crop compatibility.
- Yield increase values were sourced from SUL4R-PLUS trials and literature and may not fully reflect outcomes under variable real-world field conditions or over multiple seasons.
- Residue retention rates are assumed to be 100% for several crops, although actual field practices may include partial removal, off-site use, or straw burning.
- Carbon content and harvest index values are based on literature averages and applied uniformly across regions and cultivars, with no adjustment for local crop genetics, climate, or seasonal effects.
- Soil and biomass decomposition, nitrogen turnover, and GHG fluxes are inherently variable. Although Tier 2 approaches improve accuracy, they are still based on secondary data, not direct field measurements.
- Where data were missing (e.g. below-ground nitrogen content for peanuts), conservative assumptions were made using analogues or above-ground values.
- Carbon sequestration values reported are not eligible for carbon crediting due to the absence of permanence assessment. Dynamic modelling over a 20+ year horizon using RothC, CENTURY or DNDC would be required for that purpose.

Data and Data Quality Assessment

The activity data categories used to inform this LCA are listed in the table below. Each dataset is appropriate to the geographical region the products and raw materials are manufactured in; the data is either region-specific, or the selected generic dataset accurately reflects the intended area. The technical representativeness of the modelled processes is deemed adequate, as the data are representative both temporally and regionally, and only standard methods are employed. The Data Quality Rating (DQR) for all data provided by SUL4R-PLUS was determined. A cumulative, weighted DQR for each of these was then derived (Table A3).

Table A3. DQR Table Summary for Activity and Emission Factor Data.

Item	Activity Data DQR	Emission Factor DQR	Total DQR
Wet Raw Gypsum	1	1.4	2.4
Ammonium Lignosulfonate Solution	1	1.5	2.5
Red Waxy Corn Oil	1	2.0	3.0
Natural Gas	1	1.0	2.0
Electricity	1	1.0	2.0
Transport of Wet Raw Gypsum to Area of Manufacture	1	1.3	2.3
Transport of Ammonium Lignosulfonate to Site of Manufacture	1	1.3	2.3
Transport of Red Waxy Corn Oil to Site of Manufacture	1	1.0	2.0
Transport of SUL4R-PLUS Product to Retailer	2	1.3	3.3
Transport of SUL4R-PLUS Product from Retailer to Customer	4	1.3	5.3
Application of SUL4R-PLUS to Field	2	1.0	3.0
Soil Carbon Sequestration (from biomass)	3	2.3	5.3
N ₂ O Emissions (soil, from biomass)	3	2.3	5.3

Both emission factors and activity data are to be evaluated using the following indicators:

- 1) Technological relevance.
- 2) Temporal coverage.
- 3) Geographical coverage.
- 4) Completeness/Precision.

The data quality metric is further explained and related to uncertainty below in Table A4 (page 38).

Table A4. Combined Data Quality Rating Table, Evaluation of Overall Data Reliability Based on Activity Data Accuracy and Emission Factor Quality

Combined DQR (AD DQR + EF DQR)	Overall Data Quality Level	Description	Uncertainty
≤ 3	Excellent	Activity data and emission factors are fully robust, measured, and reported with high confidence.	Very Low Uncertainty (≤10%)
> 3 and ≤ 4.5	Very Good	Data is generally robust with minimal assumptions, meeting most indicators.	Low Uncertainty (10–20%)
> 4.5 and ≤ 6	Good	Some assumptions made in activity data and emission factors; moderately reliable.	Low-Moderate Uncertainty (20–30%)
> 6 and ≤ 7.5	Fair	Significant assumptions in activity data and emission factors; reliability is questionable.	Moderate Uncertainty (30–40%)
> 7.5	Poor	Heavily assumed data with unreliable emission factors; low confidence in results.	High Uncertainty (≥40%)

Appendix A

Table A5. Soil carbon sequestration and nitrous oxide (N₂O) emissions modelled for the use phase (Module B1) of the baseline. Results are disaggregated by crop type, U.S. region, and tillage practice, reported in kg CO₂e per acre per crop cycle (functional unit). (Full Biomass Flux)

Crop Type	Location	Soil Carbon Sequestration			Biogenic Emissions
		Conventional Till (kg CO ₂ e/FU)	Reduced Till (kg CO ₂ e/FU)	No-till (kg CO ₂ e/FU)	N ₂ O Emissions (kg CO ₂ e/FU)
Alfalfa	Midwest states	-934.88	-1,075.12	-1,215.35	367.56
Alfalfa	Southeast states	-637.42	-733.03	-828.65	367.56
Alfalfa	Great Plains/Western states	-552.43	-635.30	-718.16	367.56
Corn	Midwest states	-1,836.96	-2,112.50	-2,388.05	239.30
Corn	Southeast states	-1,252.47	-1,440.34	-1,628.21	239.30
Corn	Great Plains/Western states	-1,085.48	-1,248.30	-1,411.12	239.30
Cotton	Midwest states	-817.13	-939.70	-1,062.27	285.76
Cotton	Southeast states	-557.13	-640.71	-724.28	285.76
Cotton	Great Plains/Western states	-482.85	-555.28	-627.71	285.76
Peanut	Midwest states	-1,115.84	-1,283.22	-1,450.59	369.44
Peanut	Southeast states	-760.80	-874.92	-989.04	369.44
Peanut	Great Plains/Western states	-659.36	-758.26	-857.17	369.44
Rice	Midwest states	-1,580.16	-1,817.18	-2,054.20	271.05
Rice	Southeast states	-1,077.38	-1,238.99	-1,400.59	271.05
Rice	Great Plains/Western states	-933.73	-1,073.79	-1,213.85	271.05
Soybean	Midwest states	-939.43	-1,080.34	-1,221.25	120.66
Soybean	Southeast states	-640.52	-736.60	-832.67	120.66
Soybean	Great Plains/Western states	-555.12	-638.38	-721.65	120.66
Wheat	Midwest states	-518.24	-595.97	-673.71	77.25
Wheat	Southeast states	-353.34	-406.34	-459.35	77.25
Wheat	Great Plains/Western states	-306.23	-352.17	-398.10	77.25

Table A6. Net GHG emissions from the use phase (Module B1) of the baseline study, representing the combined effect of soil carbon sequestration and N₂O emissions. Values are reported per acre per crop cycle and disaggregated by crop, region, and tillage type. (Full Biomass Flux)

Crop Type	Location	Net GHG Emissions		
		Conventional Till (kg CO ₂ e/FU)	Reduced Till (kg CO ₂ e/FU)	No-till (kg CO ₂ e/FU)
Alfalfa	Midwest states	-567.32	-707.55	-847.79
Alfalfa	Southeast states	-269.86	-365.47	-461.09
Alfalfa	Great Plains/Western states	-184.87	-267.73	-350.60
Corn	Midwest states	-1,597.66	-1,873.20	-2,148.74
Corn	Southeast states	-1,013.17	-1,201.04	-1,388.91
Corn	Great Plains/Western states	-846.17	-1,009.00	-1,171.82
Cotton	Midwest states	-531.37	-653.94	-776.51
Cotton	Southeast states	-271.38	-354.95	-438.52
Cotton	Great Plains/Western states	-197.09	-269.52	-341.95
Peanut	Midwest states	-746.40	-913.78	-1,081.16
Peanut	Southeast states	-391.36	-505.48	-619.60
Peanut	Great Plains/Western states	-289.92	-388.83	-487.73
Rice	Midwest states	-1,309.11	-1,546.13	-1,783.16
Rice	Southeast states	-806.33	-967.94	-1,129.55
Rice	Great Plains/Western states	-662.68	-802.74	-942.80
Soybean	Midwest states	-818.77	-959.68	-1,100.60
Soybean	Southeast states	-519.86	-615.94	-712.02
Soybean	Great Plains/Western states	-434.46	-517.73	-600.99
Wheat	Midwest states	-440.99	-518.72	-596.46
Wheat	Southeast states	-276.09	-329.09	-382.10
Wheat	Great Plains/Western states	-228.98	-274.92	-320.85

Table A7. Comparison of baseline and SUL4R-PLUS-treated soil carbon additions, reported in megagrams of carbon (Mg C) per acre per crop cycle (functional unit). Values are disaggregated by crop type, U.S. region, and tillage practice. Results reflect modelled additions to soil organic carbon based on biomass inputs for both baseline and SUL4R-PLUS field trial conditions. (Full Biomass Flux)

Crop Type	Location	Baseline, Soil Carbon Addition			SUL4R-PLUS, Soil Carbon Addition		
		Conventional Till (Mg C/FU)	Reduced Till (Mg C/FU)	No-till (Mg C/FU)	Conventional Till (Mg C/FU)	Reduced Till (Mg C/FU)	No-till (Mg C/FU)
Alfalfa	Midwest states	0.255	0.293	0.332	0.355	0.408	0.461
Alfalfa	Southeast states	0.174	0.200	0.226	0.242	0.278	0.314
Alfalfa	Great Plains/Western states	0.151	0.173	0.196	0.210	0.241	0.272
Corn	Midwest states	0.501	0.577	0.652	0.508	0.585	0.661
Corn	Southeast states	0.342	0.393	0.444	0.347	0.399	0.451
Corn	Great Plains/Western states	0.296	0.341	0.385	0.300	0.345	0.391
Cotton	Midwest states	0.223	0.256	0.290	0.250	0.287	0.325
Cotton	Southeast states	0.152	0.175	0.198	0.170	0.196	0.221
Cotton	Great Plains/Western states	0.132	0.152	0.171	0.148	0.170	0.192
Peanut	Midwest states	0.305	0.350	0.396	0.336	0.387	0.437
Peanut	Southeast states	0.208	0.239	0.270	0.229	0.264	0.298
Peanut	Great Plains/Western states	0.180	0.207	0.234	0.199	0.228	0.258
Rice	Midwest states	0.431	0.496	0.561			
Rice	Southeast states	0.294	0.338	0.382			
Rice	Great Plains/Western states	0.255	0.293	0.331	0.463	0.532	0.602
Soybean	Midwest states	0.256	0.295	0.333	0.316	0.363	0.410
Soybean	Southeast states	0.175	0.201	0.227	0.273	0.314	0.355
Soybean	Great Plains/Western states	0.152	0.174	0.197	0.264	0.304	0.343
Wheat	Midwest states	0.141	0.163	0.184	0.180	0.207	0.234
Wheat	Southeast states	0.096	0.111	0.125	0.156	0.179	0.203
Wheat	Great Plains/Western states	0.084	0.096	0.109	0.153	0.176	0.199

Table A8. Net baseline and SUL4R-PLUS-treated soil carbon additions, reported in megagrams of carbon (Mg C) per acre per crop cycle (functional unit). Values are disaggregated by crop type, U.S. region, and tillage practice. Results reflect modelled additions to soil organic carbon based on biomass inputs for both baseline and SUL4R-PLUS field trial conditions.

Crop Type	Location	Net, Soil Carbon Addition (SUL4R-PLUS – Baseline)		
		Conventional Till (Mg C/FU)	Reduced Till (Mg C/FU)	No-till (Mg C/FU)
Alfalfa	Midwest states	0.100	0.114	0.129
Alfalfa	Southeast states	0.068	0.078	0.088
Alfalfa	Great Plains/Western states	0.059	0.068	0.076
Corn	Midwest states	0.007	0.008	0.009
Corn	Southeast states	0.005	0.006	0.006
Corn	Great Plains/Western states	0.004	0.005	0.005
Cotton	Midwest states	0.027	0.031	0.035
Cotton	Southeast states	0.018	0.021	0.024
Cotton	Great Plains/Western states	0.016	0.018	0.021
Peanut	Midwest states	0.032	0.036	0.041
Peanut	Southeast states	0.022	0.025	0.028
Peanut	Great Plains/Western states	0.019	0.022	0.024
Rice	Midwest states	0.208	0.239	0.270
Rice	Southeast states	0.059	0.068	0.077
Rice	Great Plains/Western states	0.099	0.113	0.128
Soybean	Midwest states	0.113	0.129	0.146
Soybean	Southeast states	0.039	0.044	0.050
Soybean	Great Plains/Western states	0.060	0.069	0.077
Wheat	Midwest states	0.069	0.080	0.090
Wheat	Southeast states	0.100	0.114	0.129
Wheat	Great Plains/Western states	0.068	0.078	0.088

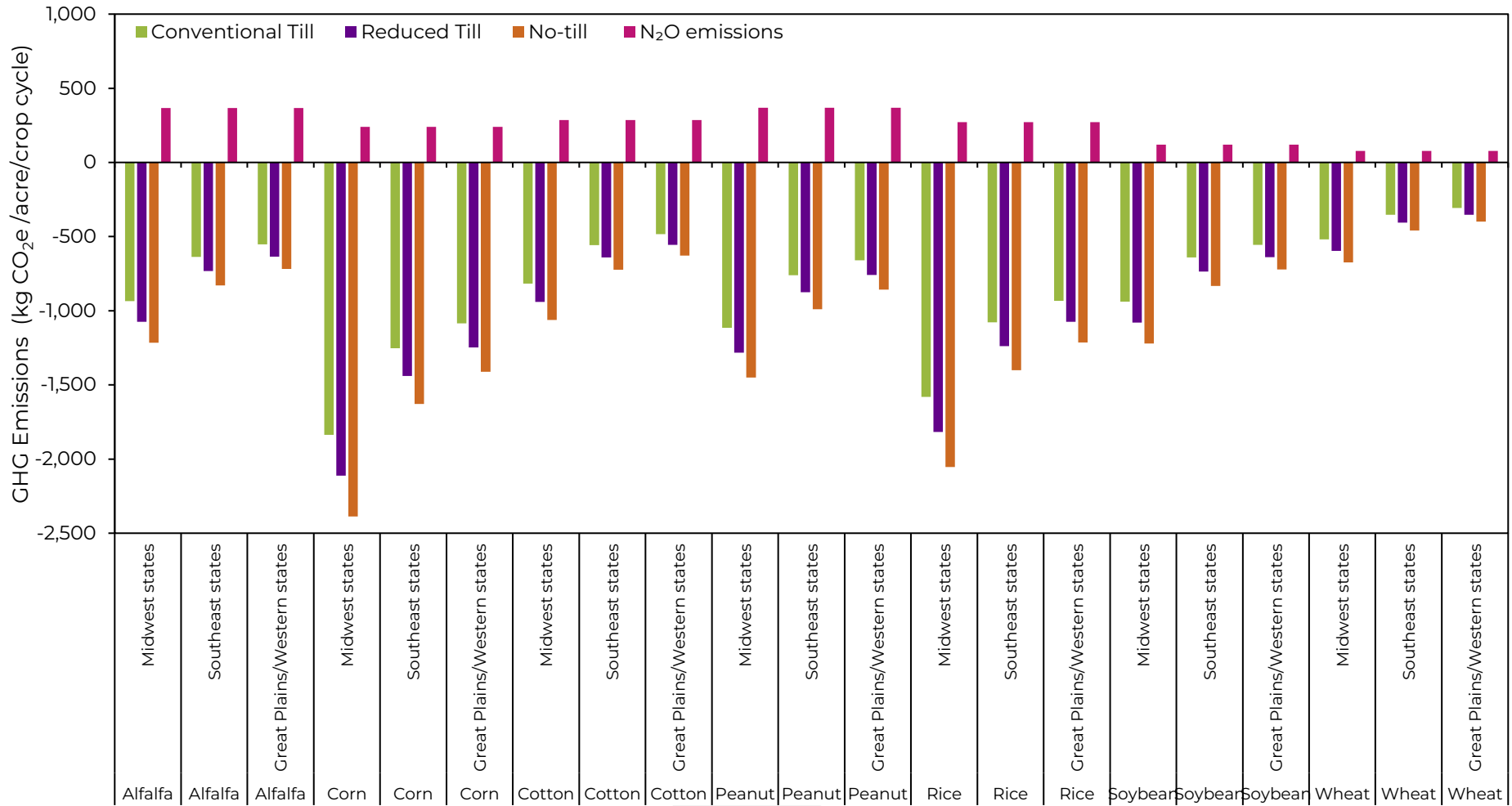

Figure A1. GHG emissions during the use phase (Module B1) of baseline field data, disaggregated by crop, U.S. region, and tillage type. Emissions are reported in kg CO₂e per acre per crop cycle. Bars represent soil carbon sequestration under conventional tillage (green), reduced tillage (purple), and no-till (orange), with nitrous oxide (N₂O) emissions displayed separately (pink) to illustrate the relative impact of soil-based emissions versus carbon removals. (Full Biomass Flux)

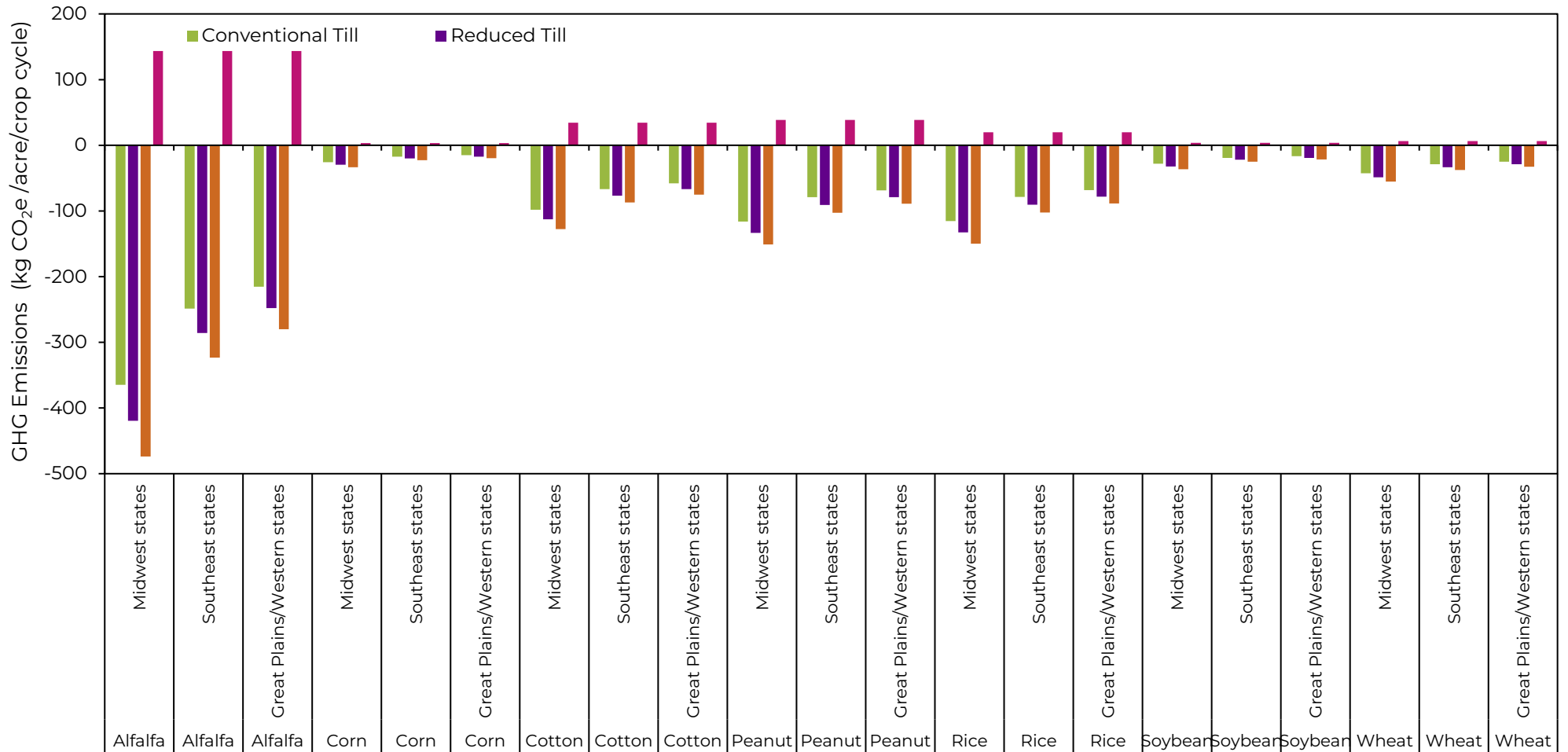

Figure A2. GHG emissions during the use phase (Module B1) for SUL4R-PLUS-Attributed removals and emissions, disaggregated by crop, U.S. region, and tillage type. Emissions are reported in kg CO₂e per acre per crop cycle. Bars represent soil carbon sequestration under conventional tillage (green), reduced tillage (purple), and no-till (orange), with nitrous oxide (N₂O) emissions displayed separately (pink) to illustrate the relative impact of soil-based emissions versus carbon removals. (SUL4R-PLUS-Attributed)

Table A9. LCA module (A1 – B1) emissions of the SUL4R-PLUS fertilizer product, reported in kilograms of carbon dioxide equivalents per functional unit (FU), one acre of land treated with SUL4R-PLUS and cultivated through an entire crop cycle. Including the standard deviation of the use phase. (Full Biomass Flux)

Life Cycle Stage(s)	Description	Fossil Emissions (kg CO ₂ e / FU)	Biogenic Emissions and Removals (kg CO ₂ e / FU)	Land Transformation Emissions (kg CO ₂ e / FU)	Total Emissions (kg CO ₂ e / FU)
A1	Raw Materials	19.75	-6.02	0.01	13.73
A2	Transport of Raw Materials	0.27	0.00	0.00	0.27
A3	Manufacturing	7.77	0.00	0.00	7.77
A4	Downstream Transport	1.99	0.00	0.00	1.99
A5	Application to Field	1.46	0.00	0.00	1.46
B1	Use Phase	0.00	-779.14 ± 608.24	0.00	-779.14 ± 608.24
Cradle-to-Use (A1-B1), Total:		31.24	-785.16 ± 608.24	0.01	-753.91 ± 608.24

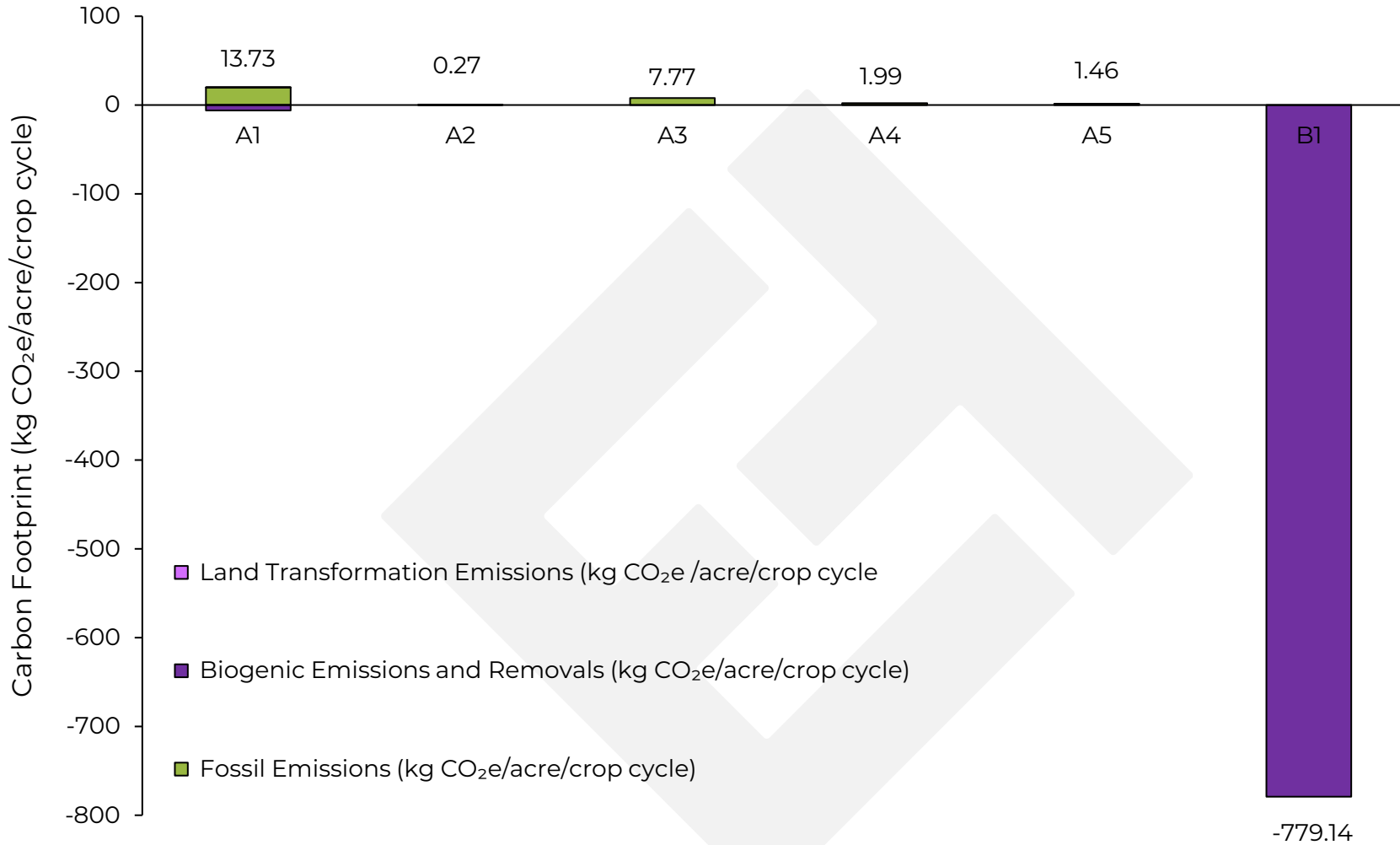

Figure A3. Breakdown of GHG emissions across life cycle stages (Modules A1–B1) for SUL4R-PLUS, reported in kg CO₂e per acre per crop cycle. (Full Biomass Flux)

Table A10. Granularity of the LCA modules (A1 – B1) emissions for the SUL4R-PLUS fertilizer product, reported in kilograms of carbon dioxide equivalents per functional unit (FU): one acre of land treated with SUL4R-PLUS and cultivated through an entire crop cycle. Including the standard deviation of the use phase (Full Biomass Flux).

Item	Life Cycle Module(s)	Fossil Emissions (kg CO ₂ e/FU)	Biogenic Emissions and Removals (kg CO ₂ e/FU)	Land Transformation Emissions (kg CO ₂ e/FU)	Total Emissions (kg CO ₂ e/FU)
Wet Raw Gypsum	A1	14.64	6.67×10 ⁻⁵	3.03×10 ⁻⁴	14.64
Ammonium Lignosulfonate Solution	A1	4.61	-6.02	5.93×10 ⁻³	-1.40
Red Waxy Corn Oil	A1	0.49	6.99×10 ⁻⁴	1.42×10 ⁻³	0.50
Transport of Wet Raw Gypsum	A2	0.01	-	-	0.01
Transport of Ammonium Lignosulfonate	A2	0.24	-	-	0.24
Transport of Red Waxy Corn Oil	A2	0.03	-	-	0.03
Natural Gas	A3	6.05	-	-	6.05
Electricity	A3	1.72	-	-	1.72
Transport to Retailer	A4	1.72	-	-	1.72
Transport from Retailer to Customer	A4	0.26	-	-	0.26
Application to Field	A5	1.46	-	-	1.46
Soil Carbon Sequestration (from biomass)	B1	-	-1062.02 ± 465.65	-	-1062.02 ± 465.65
N ₂ O Emissions (soil, from biomass)	B1	-	282.88 ± 142.59	-	282.88 ± 142.59
Cradle-to-Use (A1-B1), Total:		31.24	-785.16 ± 608.24	0.01	-753.91 ± 608.24



Approval

Author:	Dr Nathan Wood PhD, MChem
Position:	Senior Scientist and Carbon Co-lead
Written Date:	May 28 th 2025
Peer-reviewed by:	Dr Gareth Davies, PhD, MChem
Position:	Senior Scientist
Reviewed Date:	May 30 th 2025
QA approved by:	Dr Luan Ho, MEnvSc, Beng
Position:	Quality Assurance Manager
Approval date:	June 2 nd 2025
Reference:	SUL4R-PLUS-LCA_25-2
Revision:	A

Revision History:	Change Description:	Changed by:	Date:	Approved by:	Date:
B					
C					
D					
E					
F					

Tunley Environmental Report Emission Statement

Tunley Environmental GHG emissions from completing this assessment were 1.85 kg CO₂e.



IMPORTANT NOTICE:

Tunley Environmental Ltd has prepared this report and any attachments, based on an agreed scope of work, and acts as an advisor to the named Client and exercises all reasonable skill and care in the provision of its professional services, in a manner consistent with the level of care and expertise exercised by consultants in a similar environment.

Reports are commissioned by and prepared for the exclusive use of the named Client. They are subject to and issued in accordance with the agreed terms between the Client and Tunley Environmental Ltd. Tunley Environmental Ltd is not responsible and will not be liable to any other person or organisation for, or in relation to any matter dealt within this Report, or for any loss or damage suffered by any other person or organisation arising from matters dealt with or conclusions expressed in this report (including without limitation), matters arising from any negligent act or omission of Tunley Environmental Ltd, or for any loss or damage suffered by any other party relying upon the matters dealt with or conclusions expressed in this Report.

This report is not intended to be a comprehensive review of the practices of the named recipient nor the viability of its products or services. It is the responsibility of the named recipient to ensure that all its products or services adhere to and are compliant with all applicable laws, regulations and other generally accepted standards of quality and performance. Tunley Environmental Ltd accepts no liability for any failure of the products or services to meet any such standards or for any loss or other damages, (including death or personal injury) caused as a result of any such failure.

When taking any action, Recipients should not rely solely upon the report or the accuracy or completeness of any conclusions and should make their own inquiries and if they are unsure, should obtain independent advice in relation to such matters.

Except where expressly stated, Tunley Environmental Ltd has not verified the validity, accuracy or comprehensiveness of any information supplied to it, used as the background information for the writing of this report. It is assumed that the information provided to Tunley Environmental Ltd was both complete and accurate.

Information contained in the Report is current as at the date of the Report, and may not reflect any event or circumstances which occur after the date of the Report. Tunley Environmental Ltd makes no representation or guarantee that their services or this report will result in any enhancement of the Company.

COPYRIGHT STATEMENT: The concepts and information contained in this document (except the client's own copy information) are the property of Tunley Environmental Ltd, the client reserves the right to distribute. Use, copying or distribution to any third party is expressly prohibited. We do not accept any liability if this report is used for an alternative purpose from which it is intended, nor to any third party in respect of this report or of this document in whole or in part, by anyone other than the addressed recipients. Any such third-party disclosures without the written permission of Tunley Environmental Ltd constitutes an infringement of copyright.